



DLR SERIES
DVK SERIES
BLX SERIES
SX SERIES
HDX SERIES

EACH USAGE
用途別ミシン

P.3 ~ P.14



DFB SERIES
NB SERIES
BX SERIES
FX SERIES
DX SERIES
FBX SERIES

MULTI-NEEDLE
多本針二重環縫いミシン

P.15 ~ P.40

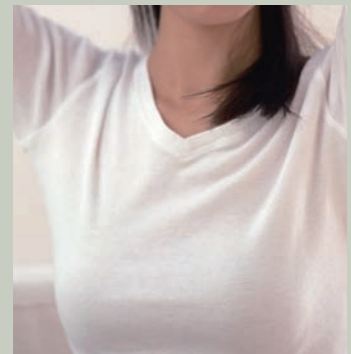

WX SERIES
LX SERIES
RX SERIES
REX SERIES
NM SERIES
FSX SERIES

TOP & BOTTOM
多本針二重環縫いミシン

P.41 ~ P.68

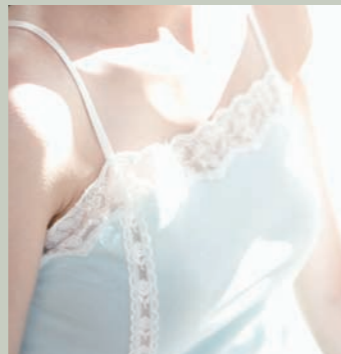

PX SERIES
MAC SERIES
MMX SERIES

DECORATION
二重環縫い飾りミシン

P.69 ~ P.76



UK SERIES

OVER LOCK
オーバーロックミシン

P.77 ~ P.82



OPTIONAL DEVICES

OPTIONAL DEVICES
オプションデバイス

P.83 ~ P.85

CONTENTS

DOUBLE CHAIN

DLR SERIES	3
DLR1503PTF	4
DLR1508P	4
DLR1509P	4
DLR1508SPF	5
DLR1509SPF	5
DVK SERIES	7
DVK1702PMD	8
B2000C	8
BLX SERIES	9
BLX2202CW	10
BLX2202PC	10
SX SERIES	11
SX6803PD	12
SX-6803DP/FL	12
HDX SERIES	13
HDX1101	14
HDX1102	14

MULTI-NEEDLE

DFB SERIES	15
DFB1404P	16
DFB1404PMD	16
DFB1404PMD (with metering device)	16
DFB1404PSF	17
DFB1406PL	17
DFB1403PSM-H	18
DFB1412PQ	19
DFB1412PS	19
DFB1412PS-ET	19
DFB1412PSSM-ET	20
DFB1412PTV	21
NB・BX SERIES	23
NB1433PSSM-ET	24
BX1433PS-SM	25
BX1033PSM	25
NB1433PQ-SM	26
FX SERIES	29
FX4404P	30
FX4404PMD	30
FX4404PMD (with metering device)	30
FX4406PL	31
FX4404PSF	31

FX4404P-UTC	32
FX4412P-UTC	32
DX SERIES	34
DX9900-4U	35
DX9902-3U	35
DX9904U	36
FBX SERIES	37
FBX1102YS	38
FBX1104P	38
FBX1106P	38
FBX1102PA-1	39
FBX1104PA-2WAC	39
FBX1102PA-2AC/LS (Lock stitch & Chain stitch)	40

TOP & BOTTOM

WX・LX SERIES	41
WX8803D	42
WX8803DW	42
WX8803D-UF	42
WX8803F	43
WX8803F-UF	43
WX8803C	44
WX8803CLW	44
WX8803EMK	44
WX8842	45
WX8842-1	45
WX8803-1S	45
WX8804D	46
LX5802LR	46
LX5802L	47
LX5802TMF	47
LX5803PHD	48
LX5801SP	49
RX・REX SERIES	51
RX9803A	52
RX9803D	52
RX9803A-UF/UTC	52
RX9803CLW	53
RX9803ALK	54
RX9803P	54
RX9803PEHK	55
RX9803PLK	56
RX9701J	56
REX9803MG	57

REX9803D	59
REX9803CL	59
NM SERIES	61
NM1103A	62
NM1103A-UF-UTC-A	62
NM1103CL-UTC-A	63
FSX SERIES	65
FSX6604S	66
FSX6604LM	66
FSX6604MH-DD	67
FSX6604MH-B	68

DECORATION

PX・MAC SERIES	69
PX302-4W	70
PX301-2S	70
PX302-5W	71
MAC100	72
MMX SERIES	73
MMX3303F	74
BX1033PSM-WMD	75
WX8803D-WD	76
RX9803CC-WD	76

OVER LOCK

UK SERIES	77
UK2005S-10M	78
UK2014H-01M	78
UK2014H-40M	78
UK2116S-30M	79
UK2116H-03X	79
UK2000H-WG	80
UK2004S-20F	80
UK2143H-90M-3x2x4	81
UK-DM	81

OPTIONAL DEVICES

OPTION	83
"DOUBLE CHAIN" シリーズ用 オプション	83
"Multi-needle" シリーズ用 オプション	83
"TOP & BOTTOM" シリーズ用 オプション	84
"Overlock" シリーズ用 オプション	85

DLR SERIES

DLR シリーズは、フラットベッド多針(1~6本針)2重環縫いマシンです。
ルーバー横振り機構の採用により中厚から厚物の縫製に最適です。ジーンズのタコ巻き縫い、腰帯付け、ゴム付けと応用範囲の広いシリーズです。
また独自に開発したプラー機構により高速運転時に送りむらも解消、安定した美しい縫い方が可能になりました。

DLR series is a flatbed, multi-needle (1~6 needles), double chain stitch machine with horizontal looper movement mechanism.
Applications: lap seaming, attaching waistbands and line tapes, and inserting elastic.
Major features of DLR series are wide range of applications on mid heavy and heavy weight fabrics and Kansai Special's unique rear puller mechanism.
These features enable DLR series to produce durable and uniform stitches on mid heavy and heavy weight fabrics.

Cama plana, multiaguja, doble cadeneta, movimiento del garfio horizontal, perfecto para materiales de mediano a extra pesados, aplicaciones sobre costura en jeans, pegar elastico, el puler tiene un mecanismo que alimenta uniformemente la tela para mejor puntada a alta velocidad.

DLR 系列是平台式多针 (1 ~ 6) 双重环缝纫机, 弯针横向运动机构使它能从中厚到厚料使用, 牛仔的卷边缝, 上腰, 上松紧等大范围使用。
独自开发的后拖轮能保证高速运转时送布均衡, 线迹美观。

DLRシリーズ モデル表示方法

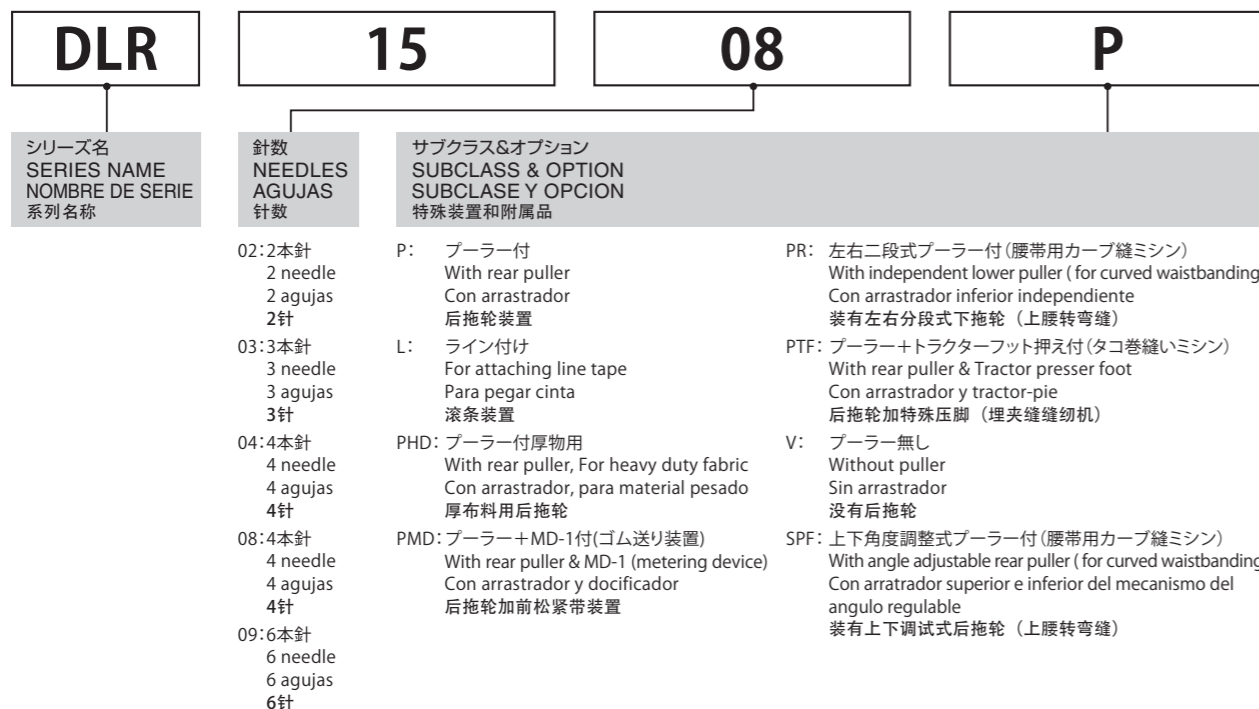

DLR1503PTF

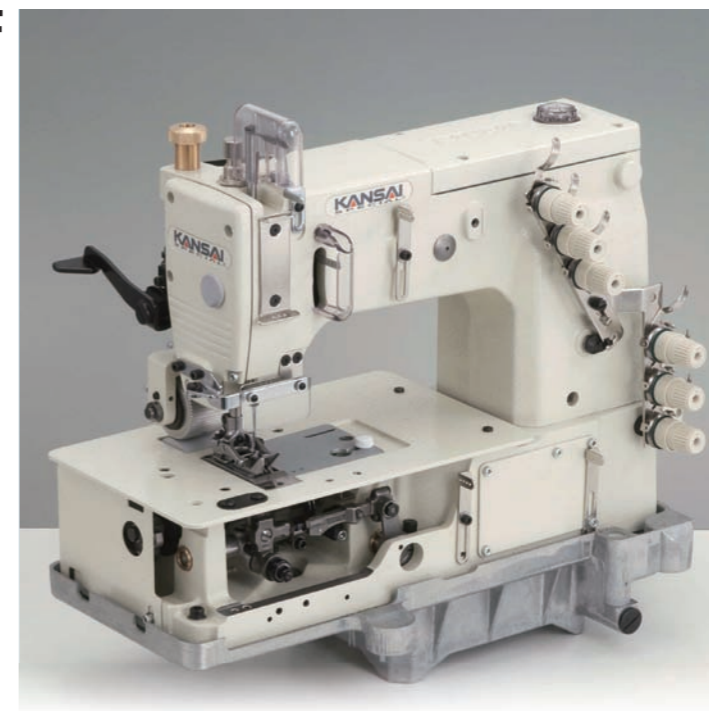

3本針二重環縫いタコ巻縫い用マシン

3 needle, flatbed, double chain stitch machine for lap seaming.

3 agujas para coser regazo.

3 针双重环缝包边缝纫机



DLR1508P DLR1509P

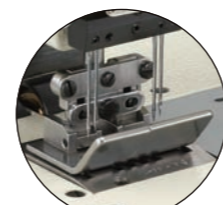

DLR-1508P



DLR-1509P

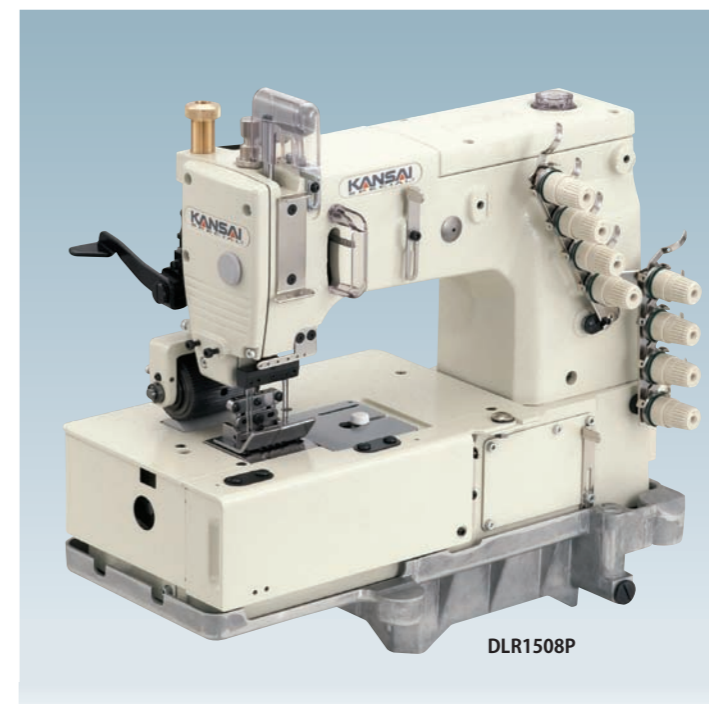

DLR1508P

4~6本針二重環縫い腰帯付け用プラー付マシン

4~6 needle, flatbed, double chain stitch machine with puller for waistbanding.

4~6 agujas (cinturera) con arrastrador.

< DLR1508P >

4 针牛仔上腰缝纫机

< DLR1509P >

6 针自由针位牛仔上腰缝纫机



MODEL	No. of Needle	No. of Thread	Needle Type		Gauge (Inch)	No. of Stitch (Stitch/Inch)	Diff. Feed Ratio	Presser Foot Lift (mm)	Needle Bar Stroke (mm)	Max. Speed (rpm)
			Organ (#)	Schmetz (Nm)						
DLR1503PTF	3	6	TV×5 21	TV×5 130	1/4, 9/32	7~16		10	34	4500
DLR1508P	4	8	TV×5 21	TV×5 130	1/4-3/4-1/4, 1/4-1-1/4, 3/16-1-3/16	7~16		10	34	4500
DLR1509P	4(6)	8(12)	TV×5 21	TV×5 130	1/8-1/8-1-1/8-1/8	7~16		10	34	4500

DLR1508SPF
(PAT・P)
DLR1509SPF

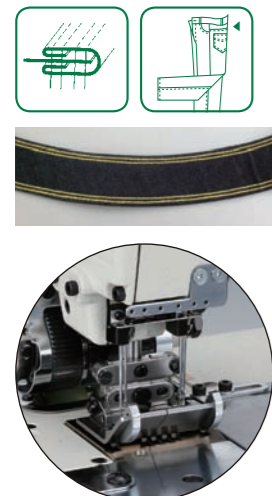

4~6本針二重環縫い腰帯付け用(カーブ縫い)上下角度調整式プラー付マシン

4~6 needle, flatbed, double chain stitch machine with upper and independent lower pullers equipped with angle-adjustable mechanism, double feed dog system for curved waistbanding.

4~6 agujas para coser curvas con mecanismo del arrastrador superior e inferior ajustable.

4~6 针双重环上腰用(转弯缝)装有上下可调后拖轮缝纫机



SPFの仕様について
(WHAT'S ABOUT SPF? / Sobre especificacion de SPF(Que es SPF?) / 对于SPF的用法(什么是SPF))

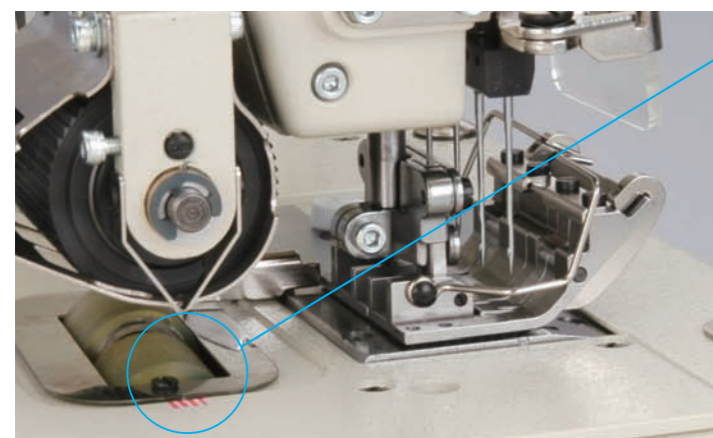

■ プラー角度調節機構(后拖轮角度可调节)
Adjustable Puller angle system
El mecanismo del angulo del arrastrador regulable

カーブ縫いの角度によって、上下プラーは回転し角度の調節が可能です。 Depending on angle of curved waistband, both upper and bottom pullers can be rotated, the indicator helps to change and fix angle of pullers.

Depende del angulo de la pretina curva, se puede hacer ajuste del angulo de arrastrador superior e inferior.

根据缝制的角度，可以调节上下拖轮的角度。

■ 2重送り歯仕様(装有双重送布牙)
Left and right-double feed dog system
El mecanismo del diente regulable

左右の送り歯の高さは、生地厚みやウエストバンドのカーブ縫いの角度によってそれぞれを調節して頂く事が可能です。

Height of left and right feed dogs can be adjusted separately according to fabric weight and the angle of curved waistband. Depende del grueso de material y el angulo de la pretina curva, separadamente se puede ajustar la altura de diente alimentador a la izquierda y la derecha.

根据左右送布牙的高度，布料的厚度，松紧带的转弯缝的角度可以做各种各样的调节来达到目的。

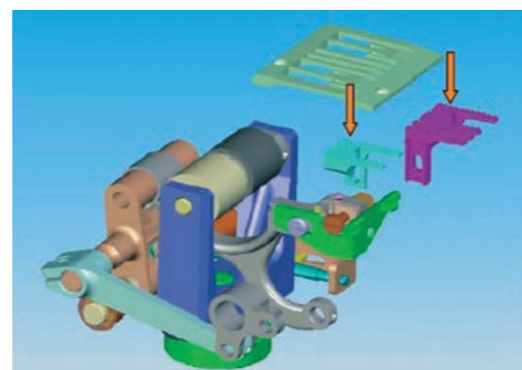

■ 1508と1509の比較(1508和1509的对比)
(Comparison between 1508P and 1509P)
(Omparacion entre 1580P y 1509P)

下図のように1509Pはゲージ交換も必要なく5種類のゲージサイズが利用できます。 As below drawing, 5 kinds of gauge sizes are available for 1509P without the conversion of gauge parts.

Como continuacion de dibujo, 5 tipos de calibres son disponibles para 1509P sin la conversion de calibre.

就像下图一样，1509P不需要更换针位就可以利用5种针位尺寸。

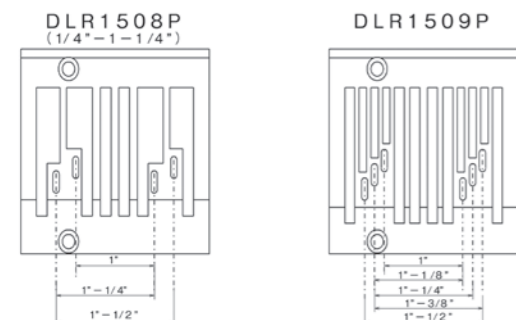

MODEL	No. of Needle	No. of Thread	Needle Type		Gauge (Inch)	No. of Stitch (Stitch/Inch)	Diff. Feed Ratio	Presser Foot Lift (mm)	Needle Bar Stroke (mm)	Max. Speed (rpm)
			Organ (#)	Schmetz (Nm)						
DLR1508SPF	4	8	TV×5 21	TV×5 130	1/4-1-1/4, 1/4-7/8-1/4	7~16		10	34	4500
DLR1509SPF	4(6)	8(12)	TV×5 21	TV×5 130	1/8-1/8-1-1/8-1/8	7~16		10	34	4500

OTHER | TECHNICAL DATA 仕様明細

MODEL	No. of Needle	No. of Thread	Needle Type		Gauge (Inch)	No. of Stitch (Stitch/Inch)	Diff. Feed Ratio	Upper Feed Amount (mm)		Presser Foot Lift (mm)	Needle Bar Stroke (mm)	Max. Speed (rpm)
			Organ (#)	Schmetz (Nm)				↔	↑			
DLR1502P	2	4	UY×128GAS 14	UY×128GAS 90	3/16, 1/4, 5/16	7~16				8	27	4500
DLR1501PHD	1	2	TV×5 21	TV×5 130		7~14				10	34	4500
DLR1502PHD	2	4	TV×5 21	TV×5 130	1/4	7~14				10	34	4500
DLR1503PHD	3	6	TV×5 21	TV×5 130	1/4	7~14				10	34	4500
DLR1502PMD	2	4	UY×128GAS 11	UY×128GAS 75	3/16, 1/4, 5/16	8~16				8	27	4500
DLR1504P	4	8	UY×128GAS 14	UY×128GAS 90	1, 1-1/8	6~16				10	34	4500
DLR1504PMD	4	8	UY×128GAS 14	UY×128GAS 90	1, 1-1/8	6~16				10	34	4500
DLR1508PR	4	8	TV×5 21	TV×5 130	1/4-1-1/4, 3/16-1-3/16	7~16				10	34	4500
DLR1502V	2	4	UY×128GAS 14	UY×128GAS 90	3/16, 1/4, 5/16, 3/8, 1/2, 3/4	7~17				8	27	4500
DLR1503V	3	6	UY×128GAS 14	UY×128GAS 90	1/4	7~17				8	31	4500
DLR1502VHD	2	4	TV×5 21	TV×5 130	3/16, 1/4, 3/8	6~12				10	34	4500
DLR1503VHD	3	6	TV×5 21	TV×5 130	1/4	6~12				10	34	4500
DLR1503VTF	3	6	TV×5 21	TV×5 130	1/4	6~12				10	34	4500

DVK・B SERIES

DVK・Bシリーズは、フラットベッド、1~2本針の二重環縫いミシンです。
ベルトループ縫いモデル(Bシリーズ)から、下着、水着のゴム付け(ゴム入れ)、極厚物のテント地、帆布、袋縫いまで幅広い製品に対応できるモデルです。

DVK・B series is a flatbed, 1-2 needle, double chain stitch and bottom cover stitch machine. Suitable for belt looping (B series), attaching and inserting elastic and sewing heavy fabrics. Major feature of DVK series is wide range of applications for ultra heavy weight fabrics such as tent fabrics, sail fabrics and bag fabrics.

Cama plana de 1-2 agujas doble cadeneta un margen ancho para aplicaciones como unir elastico a ropa interior, vestidos de baño, tambien para telas pesadas carpas, y formacion de t alegas, etc. Incluyendo maquina de pesadores(B series).

D V K 系列是平台式 1-2 针双重环缝纫机。适合裤耳机型号 < B 系列 > 内衣，游泳衣的上松紧，超厚物帐篷，帆布，袋等各种产品使用。

DVK・Bシリーズ モデル表示方法

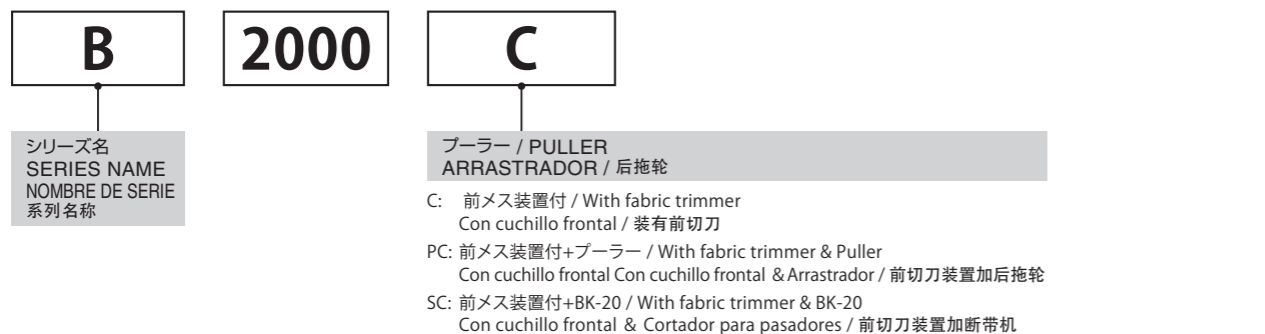
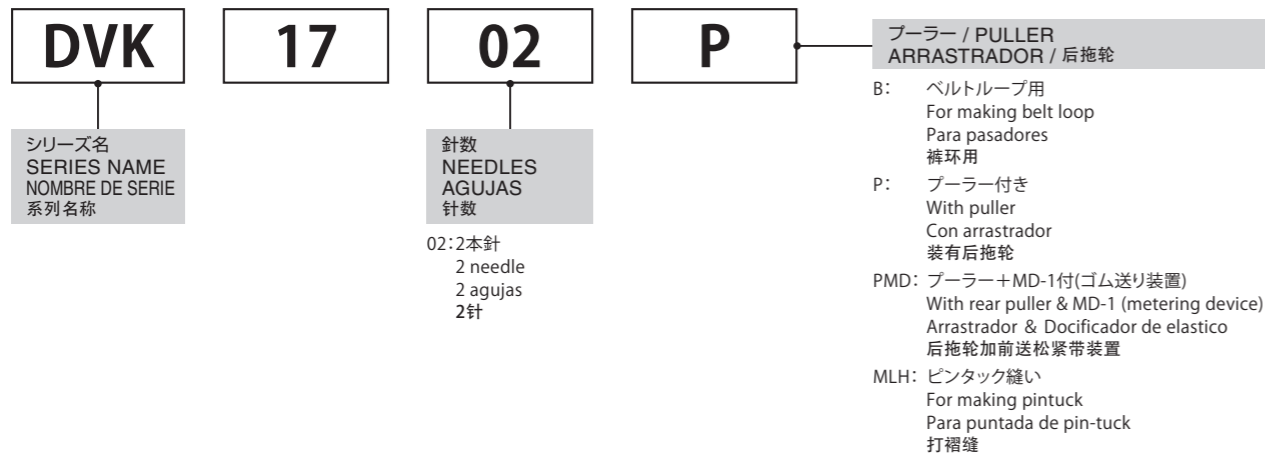

DVK1702PMD

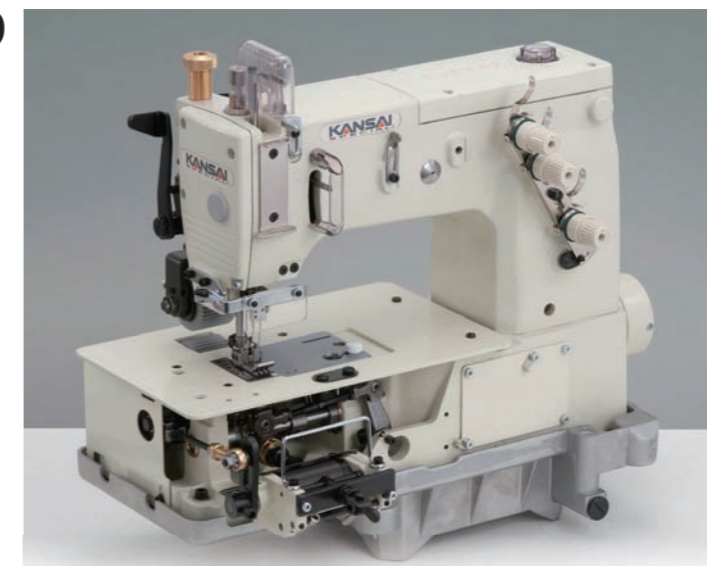
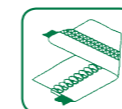

2本針下面飾りゴム付け用ミシン

2 needle, flatbed, bottom cover stitch machine for attaching elastic.

Maquina de 2 agujas con recubridor inferior para pegar elasticos.

双针下装饰用松紧带缝纫机
(带送松紧带装置)



MODEL	No. of Needle	No. of Thread	Needle Type		Gauge (Inch)	No. of Stitch (Stitch/Inch)	Diff. Feed Ratio	Presser Foot Lift (mm)	NeedleBar Stroke (mm)	Max. Speed (rpm)
			Organ (#)	Schmetz (Nm)						
DVK1702P	2	3	UY×128GAS 11	UY×128GAS 75	1/8, 5/32, 3/16, 7/32, 1/4	8~16		8	31	4500
DVK1702PMD	2	3	UY×128GAS 11	UY×128GAS 75	1/8, 5/32, 3/16, 7/32, 1/4	8~16		8	31	4500

B2000C

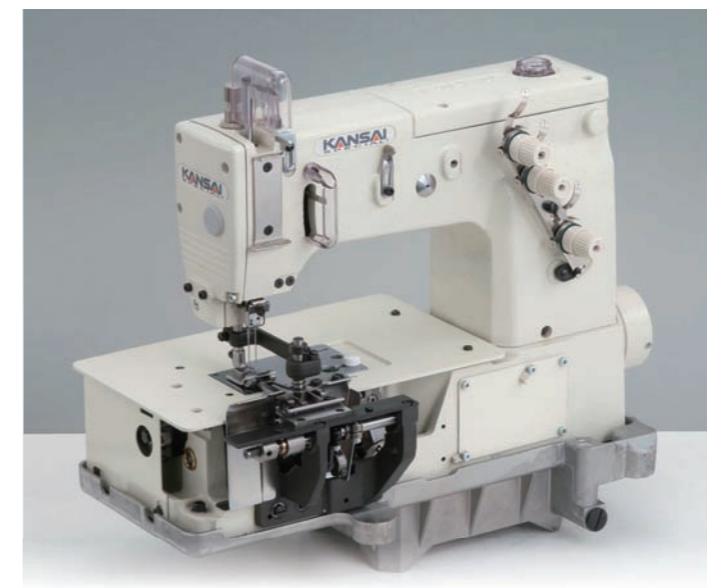

2本針、前メス付ベルトループミシン

2 needle, flatbed, making belt loop machine with front fabric trimmer.

2 agujas, para fabricar pasadores, con cuchillo frontal.

双针、双重环缝带前剃刀、裤环用缝纫机

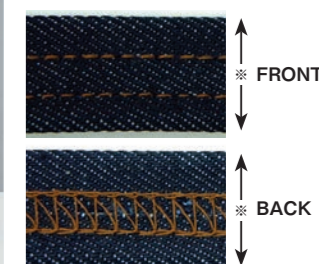

※ loop size 8mm ~ 18mm

MODEL	No. of Needle	No. of Thread	Needle Type		Gauge (Inch)	No. of Stitch (Stitch/Inch)	Diff. Feed Ratio	Presser Foot Lift (mm)	NeedleBar Stroke (mm)	Max. Speed (rpm)
			Organ (#)	Schmetz (Nm)						
B2000C (DVK1702BK)	2	3	UY×128GAS 14	UY×128GAS 90	3/16, 7/32, 1/4	9~12		8	34	4500
B2000PC (DVK1702PBK)	2	3	UY×128GAS 14~16	UY×128GAS 100	3/16, 7/32, 1/4	9~12		8	34	4500

※ベルトループ用標準サイズフォルダーは1/4"ゲージ時は12mmで7/32", 3/16"時は10mmが付いています。

※Either the folder size 12mm for 1/4" gauge or 10mm for 7/32", 3/16" is equipped as standard attachment.

※带有裤环用标准拉筒 1/4" - 12mm 巾、7/32"、3/16" - 10mm 巾。

OTHER | TECHNICAL DATA 仕様明細

MODEL	No. of Needle	No. of Thread	Needle Type		Gauge (Inch)	No. of Stitch (Stitch/Inch)	Diff. Feed Ratio	Presser Foot Lift (mm)	NeedleBar Stroke (mm)	Max. Speed (rpm)
			Organ (#)	Schmetz (Nm)						
DVK1702B	2	3	UY×128GAS 14~16	UY×128GAS 100	3/16, 7/32, 1/4	9~12		8	34	4500
DVK1702MLH	2	3	UY×128GAS 16	UY×128GAS 100	1/8	8~16		8	31	4000

BLX SERIES

BLXシリーズは、フラットベッド2本針片面飾り、前メス付きベルトループ縫い用マシンです。DVKシリーズのB2000Cを更に改良した新モデルです。新モデルは

- ① 補助押えが主押えに対して独立式になり取り外しが簡単で、ストッパー機能が付き、縫い始めの生地入れフォルダーの位置合わせが非常に容易になりました(PAT.P)。
- ② 下メス調整ダイヤル機構により左右メスのパネ圧が均一に調整でき、生地を確実にカットします。
- ③ 上記②の下メス位置ダイヤル式微調整機構により、メス合わせも簡単になり仕上がりがループ幅は8~20mmまでが可能で、ループ幅16mm以上の場合には針板、送り歯幅も広くなり広範囲な製品に対応できます(PAT.P)。

BLX series is a flatbed, 2 needle, bottom cover stitch machine for belt loop making with front knives. It is a new model which has further improvement of B2000C.

New features are;

- ① The support (front) presser foot is independent against main presser foot, so that it is easily detached and also it has a stopping function to keep at lifting position. Therefore, it is extremely easy for the positioning of folder when starting to sew.
- ② Equipped with new adjusting dial of lower knives. Both spring pressure of right and left lower knives can be equally adjusted by this dial.
- ③ Adjusting knob enables you to fine-tune the cutter easily and produce belt loops from 8mm up to 20mm. For the width over 16mm, the special wide needle plate and feed dog are available.

Las series BLX es una cama plana, 2 agujas, cobertor de puntada de fondo, maquina para hacer pasador con cuchilla delantera. Es un nuevo modelo que tiene otra mejora de B2000C.

Las nuevas características son;

- ① El(delantero) prensa tela de soporte es independiente contra el prensa tela principal, por lo que se remueve facilmente y tambien tiene una funcion de para para mantener en una posicion de levantamiento. Por lo tanto, es extremadamente facil para el posicionamiento del folder cuando se inicia la costura.
- ② Equipada con nuevos ajustes de indicador para las cuchillas inferiores que pueden ser ambas ajustadas con la, presion del resorte de la cushillas inferiores(izquierda y derecha) igualmente, para que asi puedan cortar seguramente la tela.
- ③ Facil ajuste de las cuchillas superiores e inferiores. Capacidad para fabricar de 8-20mm por lo mencionado anteriormente(No.2) el nuevo ajuste del indicador de la cuchilla inferior y el ancho de los pasadores como tamaño final. En caso de aumentar a 16mm, el tamaño del ancho de la plancha y el diente estan disponibles como opcion. Por lo tanto, las series BLX tienen un amplio rango de operaciones para fabricar varios tamaños de pasadores.

BLX 系列是平台式 2 针单面绷缝，前切刀裤耳环缝的缝纫机。

DVK 系列 B-2000C 的改良后的新型号：

新型号：① 补助压脚和主压脚分开，容易取出和装上，带停位，开始缝时进布和卷边器位置调整很容易。

② 旋转钮可调整左，右下切刀的压力，保证切布料的均等。

③ 按钮式调整缝迹长度。

BLXシリーズ モデル表示方法

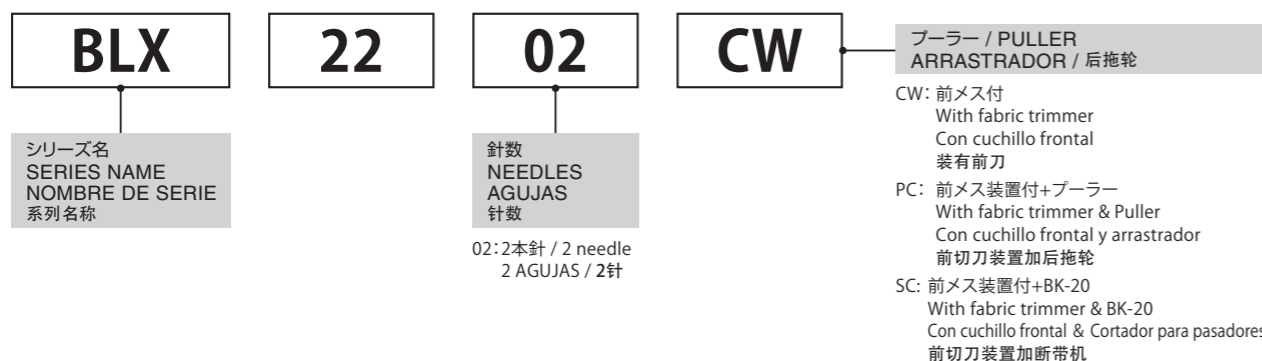

BLX2202CW



フラットベッド2本針片面飾り、前メス付きベルトループ用マシン

2 needle, flatbed, bottom cover stitch, beltloop making machine with front trimmer.

2 agujas, recubridor inferior, para la fabricacion de pasadores con cortador frontal.

双针、双重环缝带前割刀、裤耳环用缝纫机

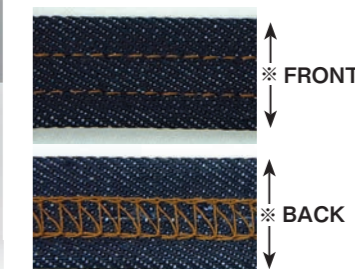

※loop size 8mm~20mm

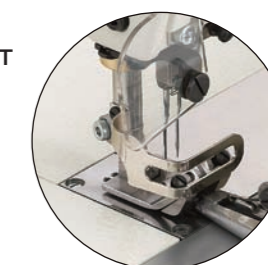

BLX2202PC



フラットベッド2本針片面飾り、前メス、プーラー付きベルトループ用マシン

2 needle, flatbed, bottom cover stitch, beltloop making machine with front trimmer and puller.

2 agujas, recubridor inferior, para la fabricacion de pasadores con cortador frontal y arrastrador.

双针裤耳机附属后拉

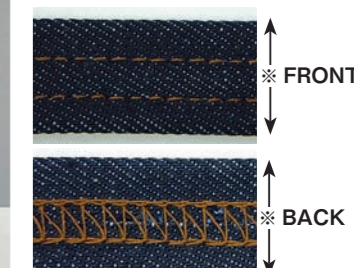

※loop size 8mm~20mm



MODEL	No. of Needle	No. of Thread	Needle Type		Gauge (Inch)	No. of Stitch (Stitch/Inch)	Diff. Feed Ratio	Presser Foot Lift (mm)	NeedleBar Stroke (mm)	Max. Speed (rpm)
			Organ (#)	Schmetz (Nm)						
BLX2202CW BLX2202SC BLX2202PC	2	3	UY × 128GAS 14~16	UY × 128GAS 100	7/32, 1/4, 3/16	9~12		8	31	4500

※ベルトループ用標準サイズフォルダーは1/4"ゲージ時は12mmで7/32", 3/16"時は10mmが付いています。

※Either the folder size 12mm for 1/4" gauge or 10mm for 7/32", 3/16" is equipped as standard attachment.

※带有裤环用标准拉筒 1/4" - 12mm巾、7/32", 3/16" - 10mm巾。



SX SERIES

SXは送り出し腕型3本針二重環縫いマシンです。
ジーンズやワーキングウェアの股縫い、脇縫いなど各種厚物生地のコ巻き縫い(ラップシーム)用マシンです。
厚物地に最適な上ローラーと差動送り機構により左右の生地がずれることなく正確に送られ、股下部の縫い合わせなどのような段部の箇所もスムーズに縫製することができます。

SX series is a 3 needle feed-off-the-arm, double chain stitch machine with upper puller. Suitable for lap seaming or side seaming on heavy weight fabrics such as jeans and working pants.
Major features help to feed the fabric uniformly so that the machine can inseam jeans even at the cross seam sections. Puckering is no longer your concern.

SX series es 3 agujas doble cadeneta-puler. Para materiales pesados, jeans, ropa de torabajo, equipada con un empujador en la parte superior para el puler, mecanismo diferencial, y poder alimentar telas pesadas, con puntadas correctas, incluyendo donde se unen varios pliegue de tela.

SX 系列为伸臂式 3 针双重链缝的缝纫机, 适合于牛仔工作服的内侧缝, 肋下缝等各种厚料的双卷边缝的上拖轮和差动送布来防止布料的股下部分缝制时的偏差, 保证缝制质量。

SXシリーズ モデル表示方法

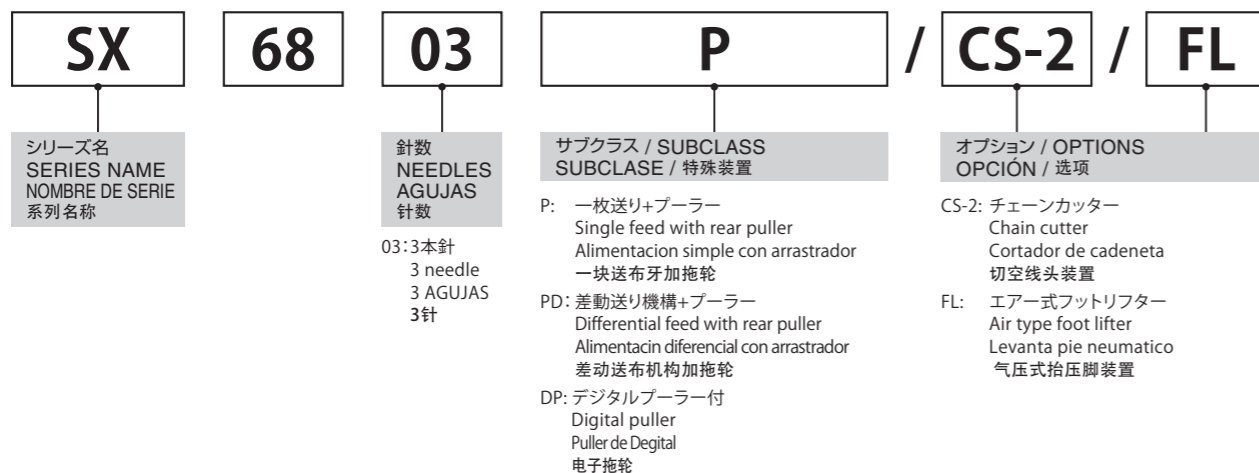

SX6803PD



SX-6803DP/FL

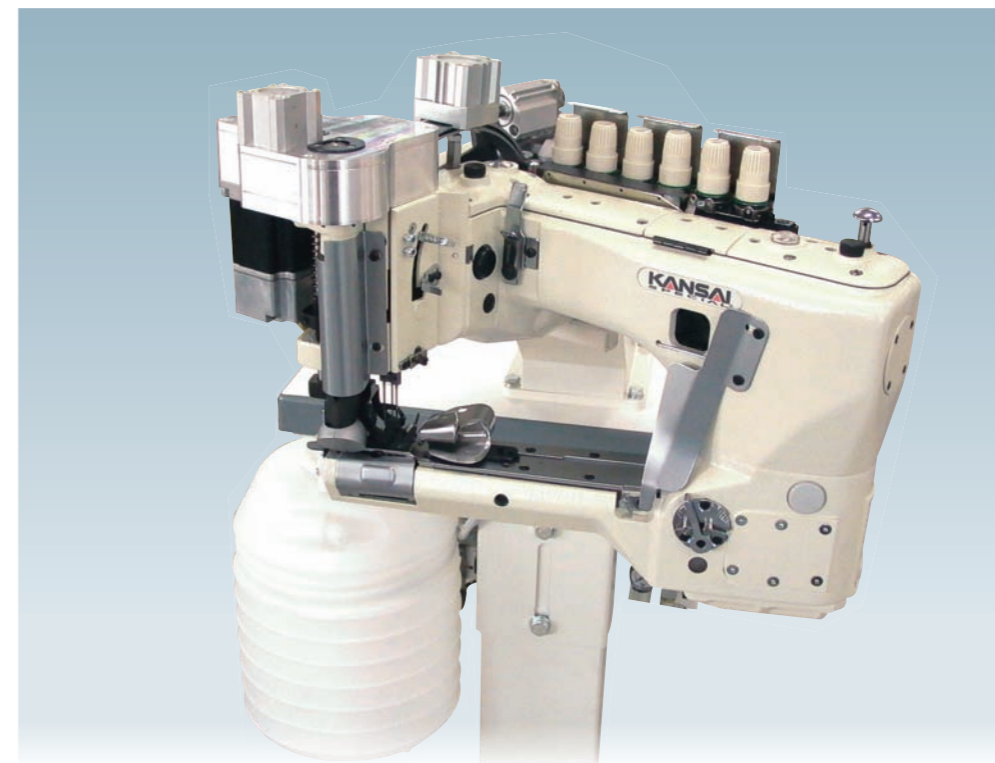

送り出し腕型3本針2重環縫い
ラップシーム用マシン

3 needle, feed-off-the-arm double
chain stitch machine for lap seaming.

Camas de brazo, 3 agujas, doble
cadeneta con mecanismo
diferencial.

伸臂式 3 针双重链缝 1 个送布牙

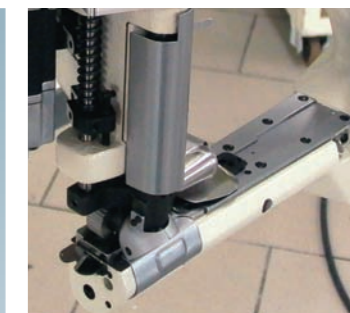

MODEL	No. of Needle	No. of Thread	Needle Type		Gauge (Inch)	No. of Stitch (Stitch/Inch)	Diff. Feed Ratio	Presser Foot Lift (mm)	Needle Bar Stroke (mm)	Max. Speed (rpm)
			Organ (#)	Schmetz (Nm)						
SX6803PD	3	6	TVX3 21	UY×128GAS 130	1/4, 9/32	6~12	0.7~1.3	8	33.3	4500
SX6803P	3	6	TVX3 21	UY×128GAS 130	1/4, 9/32	6~12		8	33.3	4500
SX-6803DP/FL	3	6	TVX3 21	UY×128GAS 130	1/4, 9/32	6~12	0.7~1.3	8	33.3	4000

※ SX-6803DP/FLはダイレクト式サーボモーター、テーブル、スタンド、エア式押し上げ装置付
 ※ SX-6803DP/FL is including direct servo motor, table, stand, air foot lifter.
 ※ SX-6803DP/FL es incluido motor directo, tabla, pata, y levanta-pie de tipo aire.
 ※ SX-6803DP/FL 是直驱式的伺服马达, 配有有机架台板, 气动式抬压脚装置



HDX SERIES

HDXシリーズは、極厚物用のフラットベッド1本針、2本針二重環縫いミシンです。
DVKシリーズのモデルDVK1701EHDを更に改良したモデルです。
針棒ストロークは48mm、水平上下運動の新送り機構を採用し、送り量は最大15mm、押え上げ量12mmという、袋縫い専用モデルです。

HDX series is flatbed, 1 or 2 needle double chain stitch machine for sewing heavy materials. It is a new model which has further improvement of DVK1701EHD. Needle stroke is 48mm. HDX series is a specialized model for Bag Forming which is equipped with max. feeding amount 15mm and 12mm height of the presser foot lift, due to the innovation of new developed feed mechanism with horizontal and up-down movements.

La serie HDX con 1 aguja, cama plana, doble cadeneta, para coser en materiales pesados, este nuevo modelo viene con adelantos referente a la maquina DVK1701EHD, el golpe de aguja es de 48mm, la serie HDX es un modelo exclusivo para la formacion de bolsas. Una alimentacion maxima de 15mm un levantado del pie de 12mm, debido al nuevo desarrollado mecanismo de alimentacion horizontal y de arriba y abajo.

HDX系列为超厚料缝平台式1针双重环缝纫机。
DVK系列的DVK-1701EHD上改良的新型号。
针棒行程48mm，水平上下运动新的送布机构。
送布量最大15mm，压脚抬高12mm用于缝各种袋。

HDXシリーズ モデル表示方法

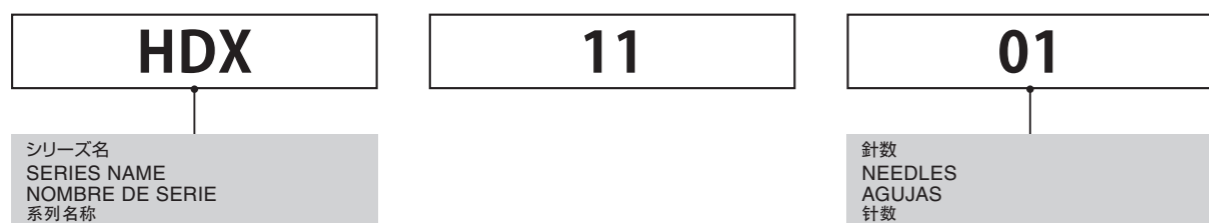

01:1本針
1 needle
1 agujas
1針
02:2本針
2 needle
2 agujas
2針

HDX1101

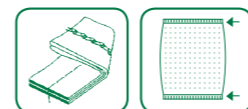

1本針二重環極厚物縫いミシン

1 needle, flatbed, double chain stitch machine for ultra heavy fabrics.

1 aguja doble cadeneta para material extra pesado.

单针双圈链锁线迹的极厚织物用缝纫机

MODEL	No. of Needle	No. of Thread	Needle Type		Gauge (Inch)	No. of Stitch (Stitch/Inch)	Diff. Feed Ratio	Presser Foot Lift (mm)	NeedleBar Stroke (mm)	Max. Speed (rpm)
			Organ (#)	Schmetz (Nm)						
HDX1101	1	2	DR X 2 25	DR X 2 200	1/4	2~4	12	48	3000	

HDX1102

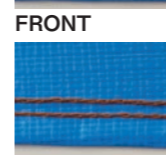
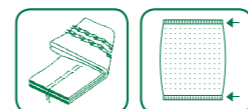

2本針二重環極厚物縫いミシン

2 needle, flatbed, double chain stitch machine for ultra heavy fabrics.

2 agujas doble cadeneta para material extra pesado.

双针缝袋机式缝纫机，用于厚料

MODEL	No. of Needle	No. of Thread	Needle Type		Gauge (Inch)	No. of Stitch (Stitch/Inch)	Diff. Feed Ratio	Presser Foot Lift (mm)	NeedleBar Stroke (mm)	Max. Speed (rpm)
			Organ (#)	Schmetz (Nm)						
HDX1102	2	4	UY X 143GS 25		1/4	2~4	12	48	3000	

DFB SERIES

DFBシリーズは、フラットベッド多本針二重環縫いマシンです。ゴム付け、ゴム入れ、前立て縫い、ライン付け、腰帯付けやスマッキング、シャーリングなど下着、スポーツウェア、婦人服、室内装飾品に至るまで汎用性に優れたモデルです。
ルーバー縦振り機構のため、2~21本針までゲージの種類も多く、針数も製品に合わせて選んでいただけます。

DFB series are flatbed, multi-needle double chain stitch machines. This series is multi-purpose such as attaching elastic, attaching waistband, sewing the front of shirts, attaching line tapes, smocking and shirring, etc., which are ideal for under wear, sports wear, lady's wear, interior decorated goods (curtains, table cloths, etc.). There are 2 up to 21 needle available due to vertical movement of the looper and also many kinds of gauges which are selectable according to your needs.

Cama plana multiagujas, doble cadeneta extremadamente versatile, para adaptar elastic, frente de camisa, puntadadecorativa y pliegues, ideal para ropa interior, ropa deportiva, cortinas, manteles, etc. Movimiento del garfio vertical, de 2 a 21 agujas con diferentes medidas para su necesidad.

DFB 系列为平台式多针机。上松紧，门襟，滚条，上腰，装饰缝等用于内衣，运动服，妇女服，室内装饰品等广范围。
弯针为纵向摆动，2-21 针的各种针位可供选择。

DFB1404P DFB1404PMD



DFB1404P

4本針平ベッド二重環縫いゴム付け用マシン。

4 needle, flatbed, double chain stitch machine for attaching elastic

4 agujas cama plana para pegar elastico.

4 针双环缝上松紧带用缝纫机 (带送松紧带装置)



DFB1404PMD (with metering device)

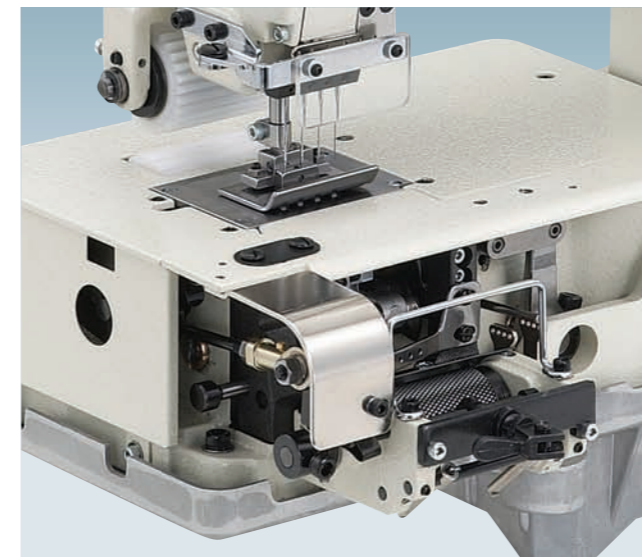

DFB・BXシリーズ 表示方法

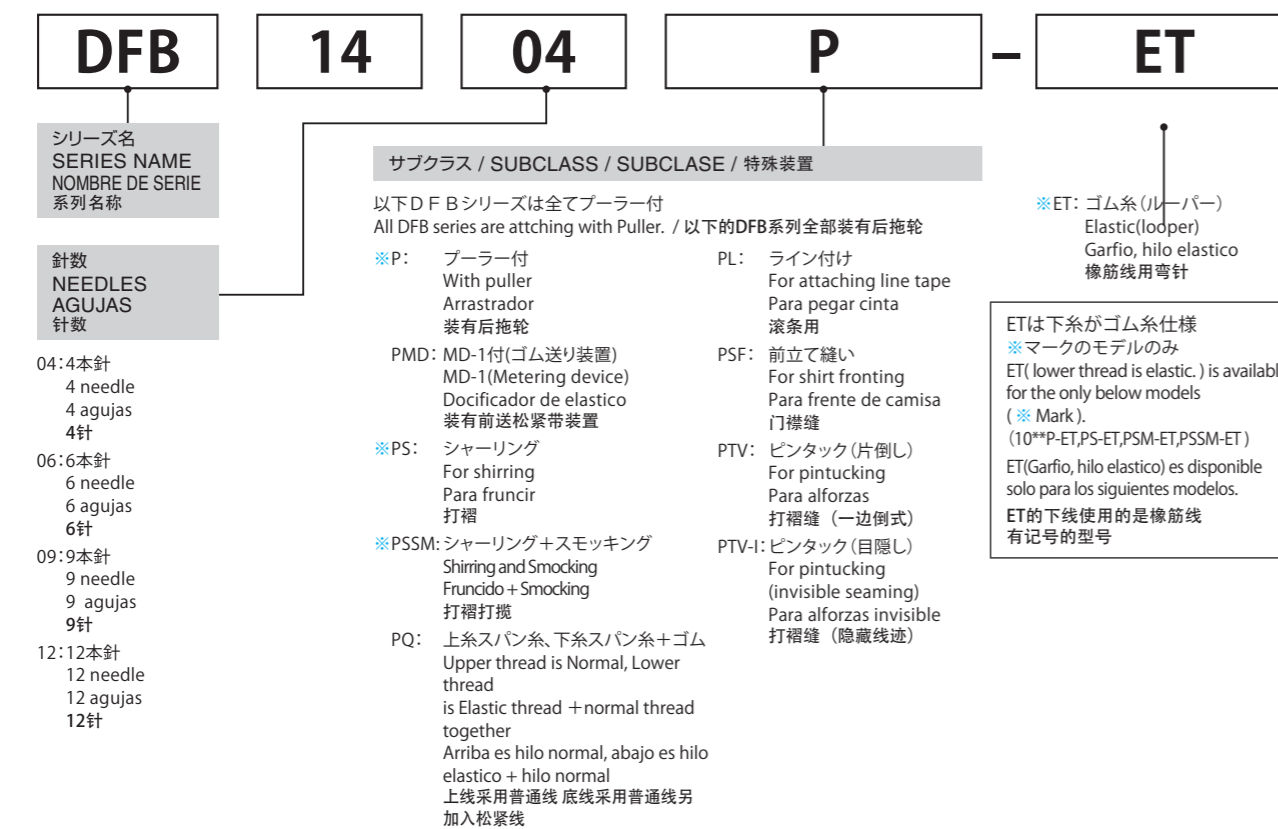

MODEL	No. of Needle	No. of Thread	Needle Type		Gauge (Inch)	No. of Stitch (Stitch/Inch)	Diff. Feed Ratio	Presser Foot Lift (mm)	Needle Bar Stroke (mm)	Max. Speed (rpm)
			Organ (#)	Schmetz (Nm)						
DFB1404P	4	8	UO×113 14	UY×113 90	3/4, 1, 1-1/8, 1-1/4, 1-1/2, 1/4-1/2-1/4	7~17		10	34	4500
DFB1404PMD	4	8	UO×113 14	UY×113 90	3/4, 1, 1-1/8, 1-1/4, 1-1/2, 1/4-1/2-1/4	8~14		10	34	4500
DFB1406P	6	12	UO×113 14	UY×113 90	3/16, 1/4, 1/3, 3/8	7~17		10	34	4500
DFB1406PMD	6	12	UO×113 14	UY×113 90	1/4	7~17		10	34	4500
DFB1408P	8	16	UO×113 14	UY×113 90	1/4	7~17		10	34	4000
DFB1408PMD	8	16	UO×113 14	UY×113 90	1/4	7~17		10	34	4000
DFB1412P	12	24	UO×113 14	UY×113 90	1/8, 3/16, 1/4, 5mm	7~17		10	34	4000
DFB1412PMD	12	24	UO×113 14	UY×113 90	3/16, 1/4	7~17		10	34	4000

DFB1404PSF

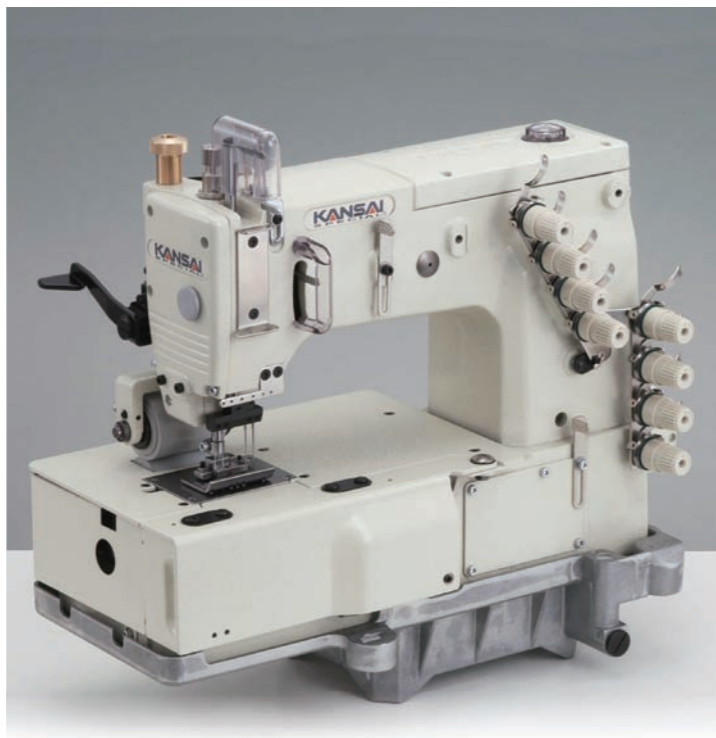

4本針前立て用マシン。
針棒ショートストロークおよび先引きローラーによりワイシャツの前立て縫いに適しています。

4 needle, flatbed multi-functional machine with smooth puller for shirt fronting.

4 agujas, para coser el frente de la camisa, equipada con arrastrador de goma.

4 针门襟用缝纫机
(由于有前导式松紧带拉料装置, 适合缝衬衫的前身片)

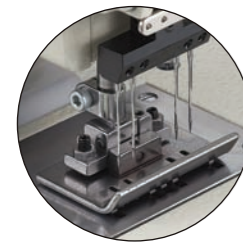

MODEL	No. of Needle	No. of Thread	Needle Type		Gauge (Inch)	No. of Stitch (Stitch/Inch)	Diff. Feed Ratio	Presser Foot Lift (mm)	NeedleBar Stroke (mm)	Max. Speed (rpm)
			Organ (#)	Schmetz (Nm)						
DFB1404PSF	4	8	UO×113 14	UY×113 90	3/16-3/4-3/16, 1/4-3/4-1/4, 3/16-1-3/16, 1/4-1-1/4	7~17		10	31	4500

DFB1406PL

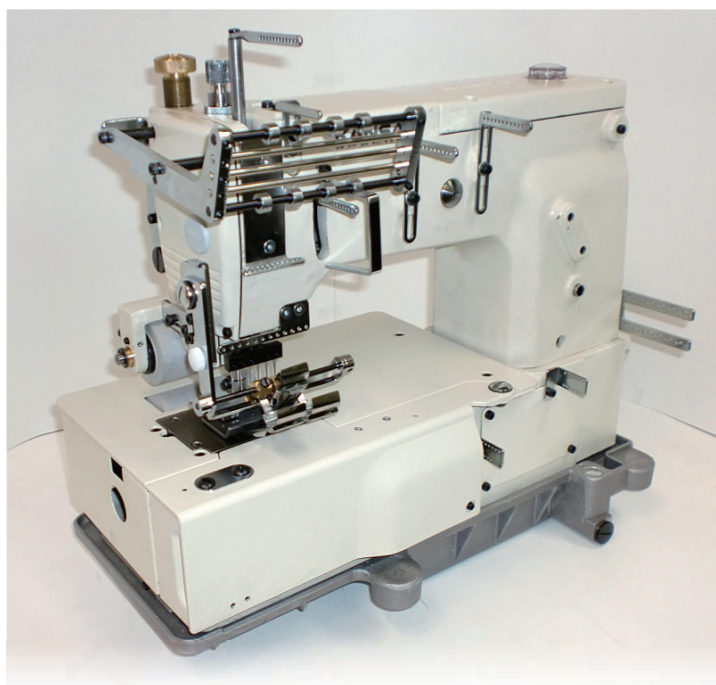

6本針二重環縫いラインテープ付け用マシン

6 needle, flatbed, double chain stitch machine for attaching line tapes.

6 agujas, maquina de cama cilindrica de doble cadeneta para pegar lineas de cinta.

6 针双重环缝, 滚条用缝纫机

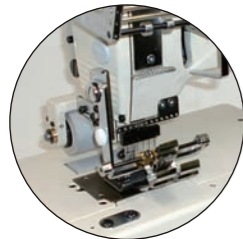

MODEL	No. of Needle	No. of Thread	Needle Type		Gauge (Inch)	No. of Stitch (Stitch/Inch)	Diff. Feed Ratio	Presser Foot Lift (mm)	NeedleBar Stroke (mm)	Max. Speed (rpm)
			Organ (#)	Schmetz (Nm)						
DFB1406PL	6	12	UO×113 14	UY×113 90	1/4, 1/3, 3/8	7~17		10	34	4500
DFB1408PL	8	16	UO×113 14	UY×113 90	1/4	7~17		10	34	4000
DFB1412PL	12	24	UO×113 14	UY×113 90	1/4, 3/16	7~17		10	34	4000

DFB1403PSM-H



3本針二重環縫いスマッキングマシン。
6種のカムによりあらゆるデザインが可能。厚物素材に適します。

3 needle, flatbed, double chain stitch machine with 6 different smocking cams. Suitable for heavy material.

3 agujas, con puntada decorativa con 6 diferentes cams. Conveniente para material pesado.

3 针双重环褶缝纫机。
用 6 种花盘所有的设计可能。

CAM NO.8

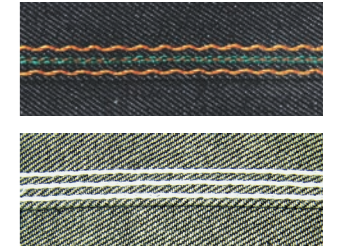

カムの種類及び模様 | Smocking Description / Descripción de Smocking / 模様盘的种类

カムの種類 CAM No.	No. 7 品番 PART No. 04-357						No. 8 品番 PART No. 04-358						No. 9 品番 PART No. 04-359						No. 10 品番 PART No. 04-360						No. 12 品番 PART No. 04-362						No. 13 品番 PART No. 04-363					
	Top Smocking Looper	Bottom Smocking Looper	Top Smocking Looper	Bottom Smocking Looper	Top Smocking Looper	Bottom Smocking Looper	Top Smocking Looper	Bottom Smocking Looper	Top Smocking Looper	Bottom Smocking Looper	Top Smocking Looper	Bottom Smocking Looper	Top Smocking Looper	Bottom Smocking Looper	Top Smocking Looper	Bottom Smocking Looper	Top Smocking Looper	Bottom Smocking Looper	Top Smocking Looper	Bottom Smocking Looper	Top Smocking Looper	Bottom Smocking Looper	Top Smocking Looper	Bottom Smocking Looper												
	[Diagram showing various smocking patterns for CAM No. 7, 8, 9, 10, 12, and 13.]																																			



オプションの押えに換えることによりポケットヘム縫いも可能です。
Optional presser foot can do also pocket hemming operation.
El pie opcional puede hacer tambien la operacion de dobladillo del bolsillo.
根据更换配件压脚, 可以缝制口袋的折下摆缝。

MODEL	No. of Needle	No. of Thread	Needle Type		Gauge (Inch)	No. of Stitch (Stitch/Inch)	Diff. Feed Ratio	Presser Foot Lift (mm)	NeedleBar Stroke (mm)	Max. Speed (rpm)
			Organ (#)	Schmetz (Nm)						
DFB1403PSM-H	3	9	DVX57 18		1/4	7~17		6	34	2000

DFB1412PQ

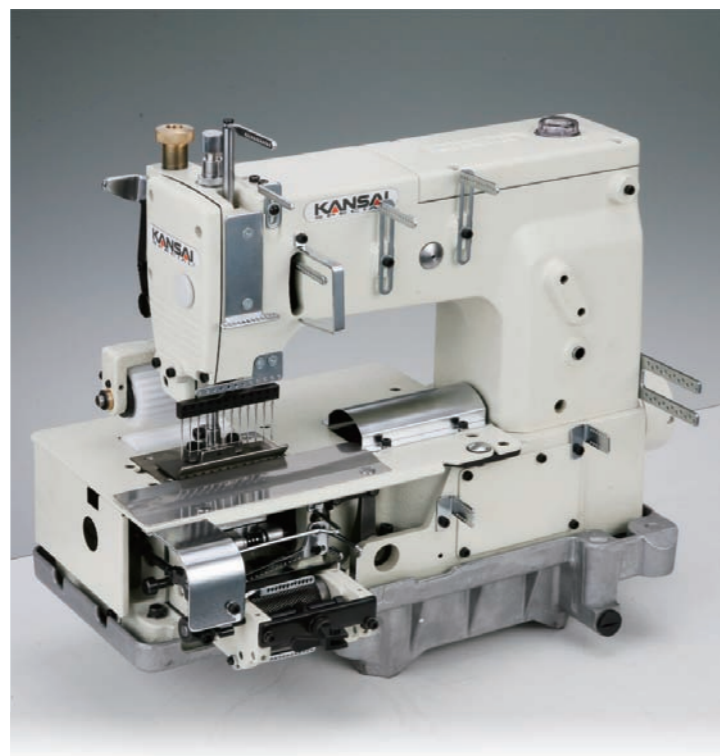

12本針2重環縫いシャーリングマシン。上下糸ともに標準糸(スパン)を使用し、ゴム糸を上下の糸に絡めて縫われます。

12 needle, flatbed, double chain stitch machine for simultaneous shirring. Both needle and looper threads are standard (spun), and separate elastic thread is sewn with looper thread together.

12 agujas, maquina de doble cadeneta para fruncido. Los dos hilos de la aguja y el looper son estandar, y el hilo elastico se cose con hilo inferior juntos.

12针双重环装饰缝绉机
(上线采用普通线 底线采用普通线另加入松紧线)

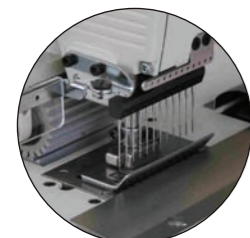
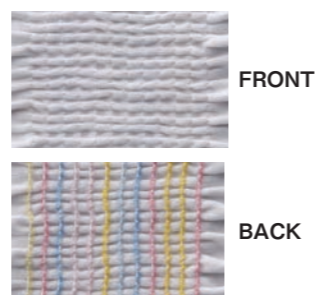

MODEL	No. of Needle	No. of Thread	Needle Type		Gauge (Inch)	No. of Stitch (Stitch/Inch)	Diff. Feed Ratio	Presser Foot Lift (mm)	Needle Bar Stroke (mm)	Max. Speed (rpm)
			Organ (#)	Schmetz (Nm)						
DFB1412PQ	12	36	DVX57 14	DVX57 90	3/16, 1/4	7~17		10	34	2500

DFB1412PS DFB1412PS-ET

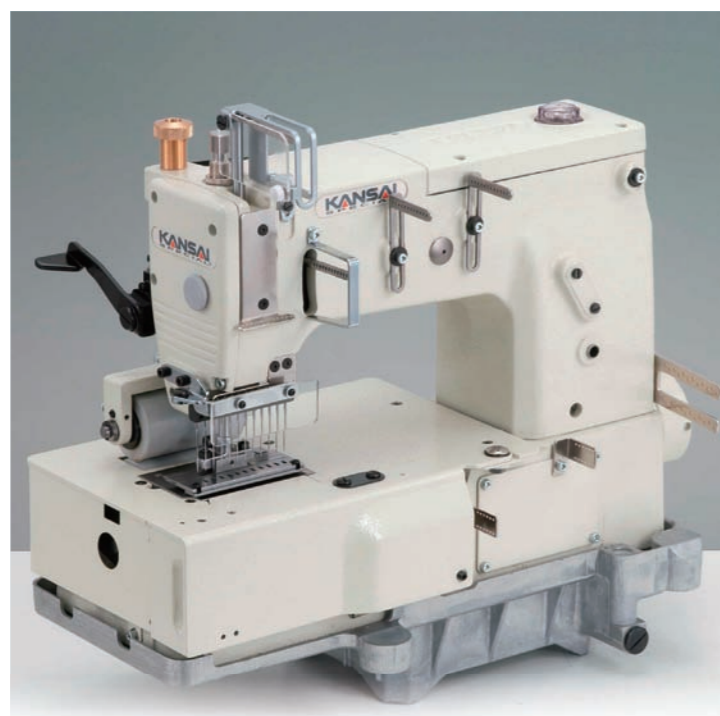

12本針2重環縫いシャーリングマシン

12 needle, flatbed, double chain stitch machine for shirring with elastic thread use in the loopers.

Cama plana de 12 agujas para pliegues.

12针双重环缝 打摺缝绉机

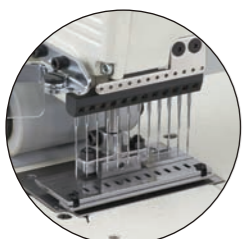
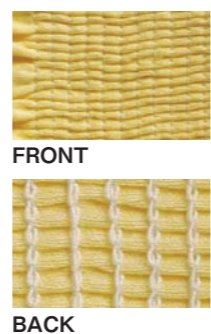

MODEL	No. of Needle	No. of Thread	Needle Type		Gauge (Inch)	No. of Stitch (Stitch/Inch)	Diff. Feed Ratio	Presser Foot Lift (mm)	Needle Bar Stroke (mm)	Max. Speed (rpm)
			Organ (#)	Schmetz (Nm)						
DFB1412PS	12	24	DV×57 14	DV×57 90	3/16, 1/4	7~17		10	34	4000
DFB1412PSET	12	24	DV×57 14	DV×57 90	3/16, 1/4	7~17		10	34	4000

DFB1412PSSM-ET

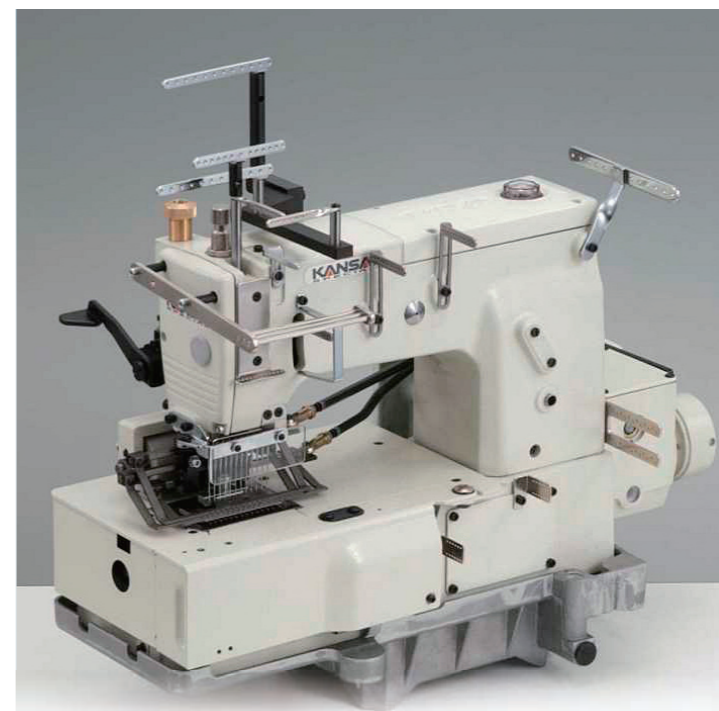

12本針2重環縫いスモッキング・シャーリングマシン

12 needle, flatbed double chain stitch machine for shirring and smocking with elastic thread inside the loopers.

12 agujas, con puntada decorativa y alforzas, el hilo elastico para looper.

12针双重环缝, 打摺打绉缝绉机

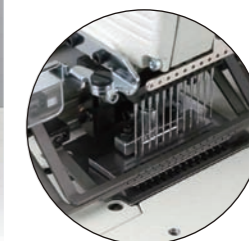

MODEL	No. of Needle	No. of Thread	Needle Type		Gauge (Inch)	No. of Stitch (Stitch/Inch)	Diff. Feed Ratio	Presser Foot Lift (mm)	Needle Bar Stroke (mm)	Max. Speed (rpm)
			Organ (#)	Schmetz (Nm)						
DFB1412PSSM	12	36	DV×57 14	DV×57 90	3/16, 1/4	7~17		6	34	2000
DFB1412PSSMET	12	36	DV×57 14	DV×57 90	3/16, 1/4	7~17		6	34	2000

DFB10 series, DFB14 series ET, PQ 比較 | comparison

MODEL	THREAD		PRESSER FOOT	LOOPER	STITCH (BACK SIDE)	
	NEEDLE	LOOPER				
DFB1012P	Elastic		TYPE A (FLAT)	19-112~17		
DFB1012PS	Elastic		TYPE B - Presser foot with 2mm, 4mm step for shirring operation			
DFB1012PSSM	Elastic		TYPE C - Flat for smocking operation			
DFB1412PSET	Standard	Elastic	Presser foot with 2mm, 4mm step for shirring operation	14-432 (ET用)		
DFB1412PSSMET	Standard	Elastic	TYPE D - Flat and Presser foot with 2mm step			
DFB1412PQ	Standard	Elastic + standard	TYPE E - Flat for PQ	14-431		
DFB1412PQSM	Standard	Elastic + standard	TYPE F - Flat for PQSM			

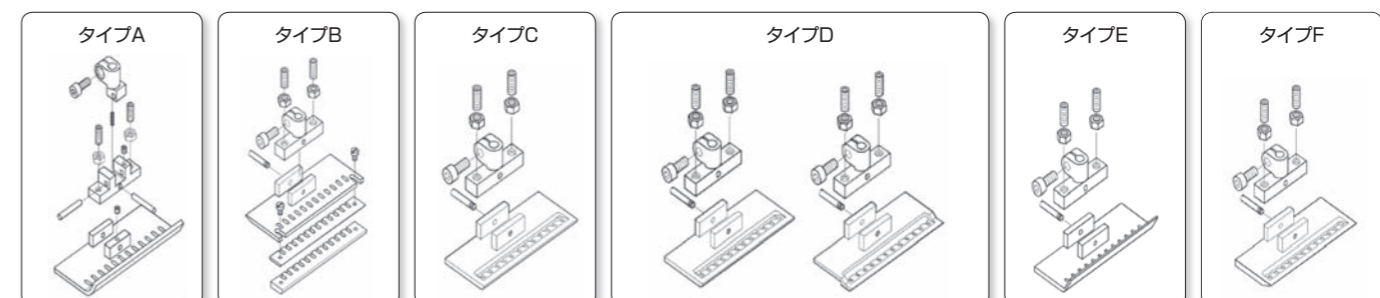

DFB1412PTV

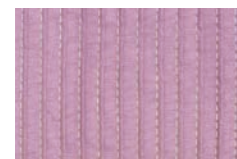

12本針二重環縫いピンタック用マシン。
タック幅は爪の交換により2mm、5mm、
8mmの3種類が可能です。

12 needle, flatbed, double chain
stitch machine for pin-tucking.
The width of pin-tucking can be
changed to 2, 5 and 8mm by
changing the nail blades.

12 agujas, looper vertical, doble
puntada en cadena, maquina de
cama plana con accesorios para
pliegues y puller.

12 针双重环缝链式打摺缝纫机
PTV 打摺幅度通过爪的更换可加工 2、5、
8mm 的 3 种规格

MODEL	No. of Needle	No. of Thread	Needle Type		Gauge (Inch)	No. of Stitch (Stitch/Inch)	Diff. Feed Ratio	Presser Foot Lift (mm)	Needle Bar Stroke (mm)	Max. Speed (rpm)
			Organ (#)	Schmetz (Nm)						
DFB1412PTV	12	24	DVX57 12	DVX57 80	3/16, 1/4	7~17		10	34	3500

■ PTV 標準仕様 / PTV standard model / PTV modelo normal / PTV modelo normal / PTV 縫明线条仔用
ビジブルタック用 / For Visible tucking / Puntada visible / Para ponto visível / 高度加摺針明細

	ピンタック折り幅 Pin tucking width Anchura de Pin Tcking PTV 打摺高度	L:左側用ガイド Left side fold Dobra lado izquierdo 左摺針	R:右側用ガイド Right side fold Dobra lado derecho 右摺針	C: 中心 Center Centro 中心
上爪 Upper guide Guia superior 喇叭上爪		13 pcs	13 pcs	1 pc
下爪 Lower guide Guia inferior 喇叭下爪	1 pc	12pcs	12pcs	
	5mm	12pcs	12pcs	
	8mm	8pcs	8pcs	

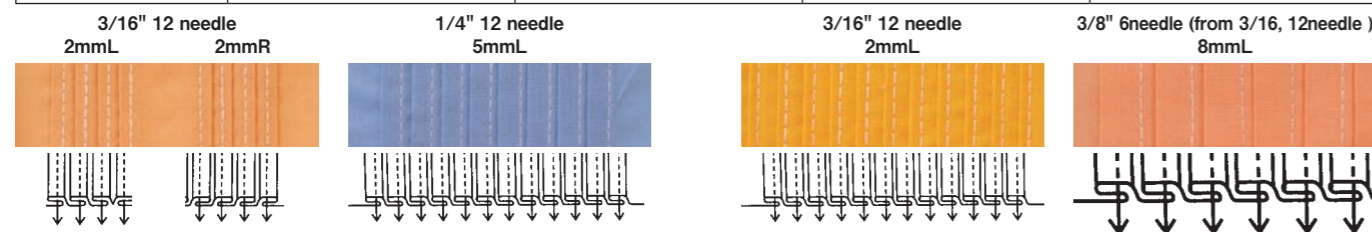

■ PTV オプション仕様 / PTV optional model / PTV modelo opcional / PTV modelo opcional / 縫暗线条仔用
PTV-I インビジブルタック用 / For Invisible tucking / Para tucking invisible / Para tucking invisível / 仕様高度加摺針明細

	ピンタック折り幅 Pin tucking width PTV Anchura de Pin Tucking 打摺高度	ゲージ幅 Gauge size Tamano de aguja 針距	L:左側用ガイド L: Left side fold Dobra lado izquierdo 左摺針	押え Presser foot Prensatela 押脚
下爪 Lower guide Guia inferior 喇叭下爪	6mm	3/16"(4.8mm)	12 pcs	専用押え Exclusive presser foot for PTV-I Prensatela exclusiva para PTV-I Pressao exclusiva para PTV-I 专用押脚
	8mm	1/4" (6.4mm)	12 pcs	
	11mm	* 3/8" (9.5mm)	6 pcs	
	14mm	* 1/2" (12.7mm)	6 pcs	

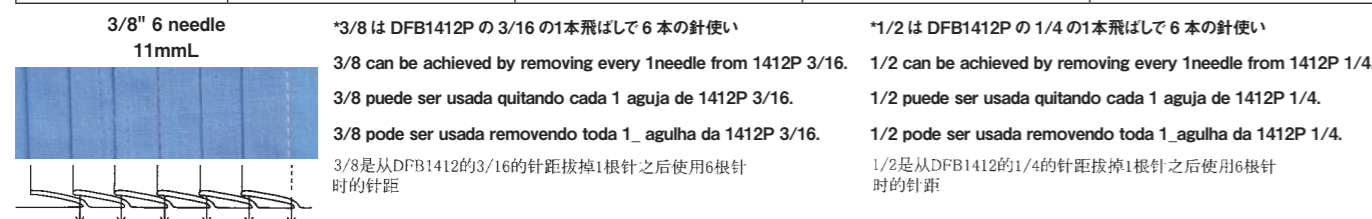

Gauge

■ 多針マシン特殊ゲージ表
Special gauge description for Multi gauge machine
Descripcion de tamaño de aguja especial para Multi agujas
Descricao de bitola especial para maquina Multi agulhas
多针缝纫机特殊针距表

MODEL	DFB1411P-XP	DFB1411SPF	DFB1421P	DFB1418P
ゲージ Gauge Calibre 针位				
	1/8-1/8-1/8-1/8-1/8-1/4- 1/4-1/8-1/8-1/8-1/8"	1/8-1/8-1/8-1/8-1/4- 1/4-1/8-1/8-1/8-1/8"	1/8"	1/8-1/8-1/8-1/8-1/4-1/8-1/8-1/4- 1/8-1/8-1/8-1/8-1/8"
糸調子セット Thread tension set Unidad de tension de hilo				
	4X4	4X4	12X12	6X6
テーブルセット図外観 Overview Perspectiva 概要				
プーラー / Puller Arrastrador / 后拖轮	Nylon gear ※Rubber/Steel gear	Steel gear / ※knurling gear	Rubber	Rubber

※ : ※印はアクセサリ—BOXに同梱 Enclosed in accessory box

OTHER TECHNICAL DATA 仕様明細

MODEL	No. of Needle	No. of Thread	Needle Type		Gauge (Inch)	No. of Stitch (Stitch/Inch)	Diff. Feed Ratio	Presser Foot Lift (mm)	Needle Bar Stroke (mm)	Max. Speed (rpm)
			Organ (#)	Schmetz (Nm)						
DFB1404WB	4	8	UO×113 18	UY×113 110	3/16-3/4-3/16, 1/4-3/4-1/4, 3/16-1-3/16, 1/4-1-1/4	7~17		10	34	4500
DFB1412PQSM	12	48	DV×57 14	DV×57 90	3/16, 1/4	7~17		6	34	2000
DFB1402MR	2	4	UO×113 14	UY×113 90	1/4	7~17		10	31	3500
DFB1412MR	12	24	UO×113 14	UY×113 90	1/4	7~17		10	31	3000
DFB1012P	12	12	DVX57LE 21		3/16, 1/4	7~17		10	34	2000
DFB1012PS	12	12	DVX57LE 21		3/16, 1/4	7~17		10	34	2000
DFB1012PSSM	12	24	DV-K25 21		3/16, 1/4	7~17		6	34	2000



NB・BX SERIES

NB・BXシリーズは、フラットベッド多本針二重環縫いミシンです。ゴム付け、ゴム入れ、前立て縫い、ライン付け、腰帯付けやスマッキング、シャーリングなど下着、スポーツウェア、婦人服、室内装飾品に至るまで汎用性に優れたモデルです。

ルーバー縦振り機構のため、25,33本針までゲージの種類も多く、針数も製品に合わせて選んでいただけます。また、BXの後継機として新たに加わったNBシリーズは、従来の25本針および33本針仕様はそのままに、デザインを一新。明るくスマートな外観に生まれ変わりました。さらにスマッキング用モデルのPSM、PSSMでは飾り糸振りを4段とし、さらに多様なスマッキングが可能になりました。

NB・BX series are flatbed, multi-needle double chain stitch machines. This series is multi-purpose such as attaching elastic, attaching waistband, sewing the front of shirts, attaching line tapes, smocking and shirring, etc., which are ideal for under wear, sports wear, lady's wear, interior decorated goods (curtains, table cloths, etc.). There are 25,33 needle available due to vertical movement of the looper and also many kinds of gauges which are selectable according to your needs. Just recently, KANSAI SPECIAL launched the "NB Series", the new model of BX Series. This NB Series has a newly shaped, modern casting. The smocking models PSM & PSSM are now equipped with 4 spreaders for the decorative threads. This innovation enables a greater variety of different designs.

Cama plana multiagujas, doble cadeneta extremadamente versatile, para adaptar elastic, frente de camisa, puntadadecorativa y pliegues, ideal para ropa interior, ropa deportiva, cortinas, manteles, etc. Movimiento del garfio vertical, de 25,33 agujas con diferentes medidas para su necesidad.

NB, BX 系列为平台式多针机。上松紧, 门襟, 滚条, 上腰, 装饰缝等用于内衣, 运动服, 妇女服, 室内装饰品等广范围。弯针为纵向摆动, 25, 33 针的各种针位可供选择。

NB・BXシリーズ 表示方法

NB	14	33	P	ET
シリーズ名 SERIES NAME NOMBRE DE SERIE 系列名称	縫目形式 SEAM TYPE TIPO DE LA COSTURA 线迹形式	針数 NEEDLES AGUJAS 针数	サブクラス&オプション SUBCLASS & OPTION SUBCLAS Y OPCION 特殊装置和附属品	※ET: ゴム糸(ルーバー) Elastic(looper) Garfio, hilo elastico 橡筋线用弯针
	14: 二重環縫い Double chain stitch Puntada de la cadena doble 双重环缝	25: 25本針 25 needle 25 agujas 25针	以下BX, NBシリーズは全てプーラー付 All NB & BX models are equipped with a real puller 以下のBX, NB系列全部装有后拖轮	ETは下糸がゴム糸仕様 ※マークのモデルのみ ET(lower thread is elastic.) is available for the only below models (※Mark). (10**P-ET, PS-ET, PSM-ET, PSSM-ET) ET(GARFIO, HILO ELASTICO) es disponible solo para los siguientes modelos. ETの下糸使用的是橡筋线 有记号的型号
	10: 単環縫い Single chain stitch Sola puntada de la cadena 单环缝(只有上线 没有下线)	33: 33本針 33 needle 33 agujas 33针	※P: プーラー付 With puller Con arrastrador 装有后拖轮	
			※PS: シャーリング For shirring Para el shirring 打褶	
			※PSSM: シャーリング+スマッキング For shirring & smocking Para el shirring, smocking 打褶打摺	
			PTV: ピンタック(片倒し) For pintucking Para el pintucking 打褶缝(一边倒式)	
			PTV-I: ピンタック(目隠し) For pintucking (invisible seaming) Para el pintucking (cosiendo invisible) 打褶缝(隐藏线迹)	

NB1433PSSM-ET



33本針ゴム糸シャーリング+スマッキング
ミシン

33 needle, flatbed double chain
stitch machine for shirring and
smocking with elastic thread
inside the loopers.

33 agujas, con puntada decorativa
y alforzas, el hilo elastico para
looper.

3 3 针平台式双重环装饰用打褶打摺缝纫机。
外观一新, 实现了更多样的装饰图案



4段のスプレッターで更なるデザインが可能に。
4 spreaders for the decorative
thread increase the number of
design patterns.
4 esparcidor de decoracion
puede aumentar mas un buen
deseno.
4段打摺条可任意变换装饰线样式。

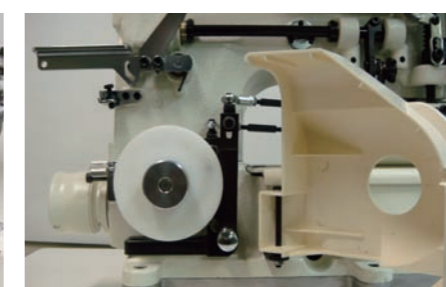

CAMのカバーの開け閉めが簡単になり
工具無しでスムーズなCAM交換が可能です。
The cam cover is easily openable
& closable. The cam is easily
changeable without tools!!
Se puede abrir la cubierta de leva
con facilidad, y cambiar la leva sin
herramienta.
模样盘的开关外壳无需用工具便可简单
更换。



レバー調節での部分シャーリングが可能に。
Lever-type adjustment enables
to make partial shirring.
Es posible hacer el fruncido
parcial como se quiera mediante
el ajuste de palanca.
调解拉杆可使打摺部分化。

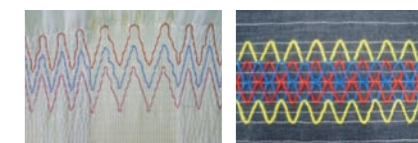

MODEL	No. of Needle	No. of Thread	Needle Type		Gauge (Inch)	No. of Stitch (Stitch/Inch)	Diff. Feed Ratio	Presser Foot Lift (mm)	Needle Bar Stroke (mm)	Max. Speed (rpm)
			Organ (#)	Schmetz (Nm)						
NB1433PSSM-ET	33	110	DV×57 14	DV×57 90	3/16	4~18	—	6	34	2000

BX1433PSSM



33本針二重環縫いシャーリング、スモッキングマシン

33 needle, flatbed, double chain stitch machine for simultaneous shirring and smocking with 9 different cams for various designs.

33 agujas; para pliegues y puntadas decorativas, con 9 diferentes cams (para varios diseños).

33 针两重环装饰缝打褶打搅缝纫机



FRONT

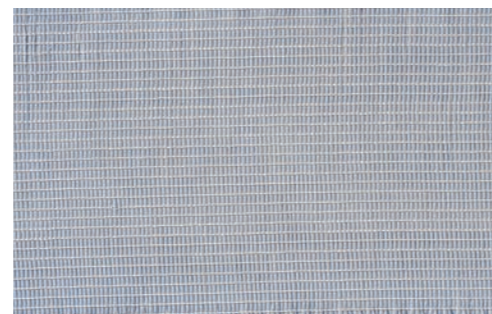

BACK

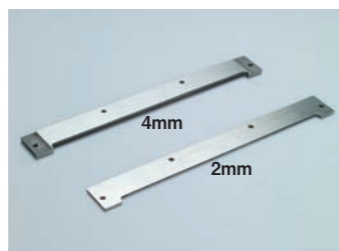

BX1033PSM



33本針単環ゴム糸用スモッキングマシン

33 needle, flatbed, single chain stitch machine for simultaneous shirring and smocking. Needle (upper) thread : Elastic. No looper (lower) thread.

33 agujas garfios verticales, una cadeneta, cama plana, para pliegues y puntada decorativa, con arrastrador.

33 针单环打褶打搅缝纫机



FRONT



BACK

NB1433PQ-SM

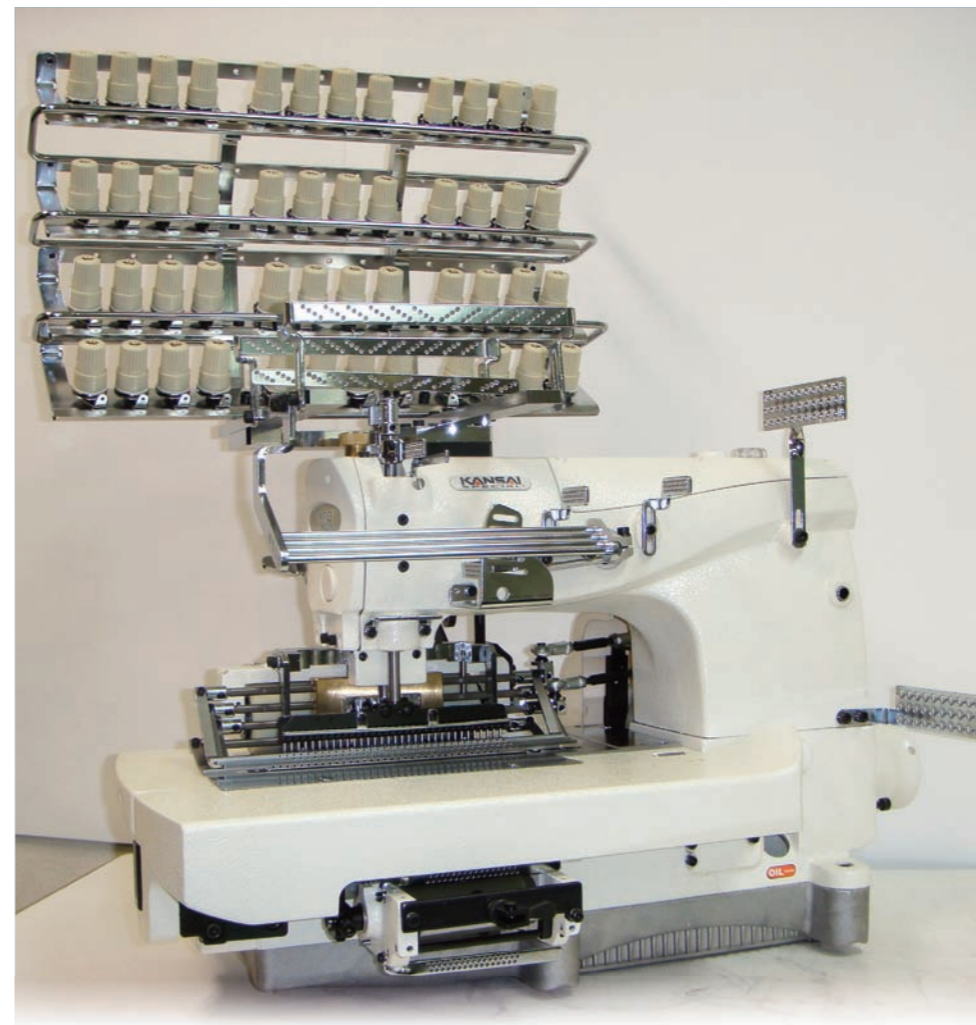

33本針二重環縫いシャーリング・スモッキングマシン

上下糸にスパン糸を使用し、下糸にゴム糸を絡めています。

33 needle flatbed, double chain stitch machine for simultaneous shirring & smocking with our patented PQ mechanism.

33 agujas, maquina de puntada de cadena doble para el shirring del simytanues & los smocking patentaron el mecanismo de PQ

3 3 针双重环缝，打褶打搅缝纫机 (上线用普通线 下线用普通线加松紧线)

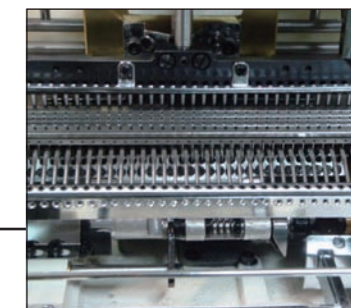

PQの縫製品の伸縮性

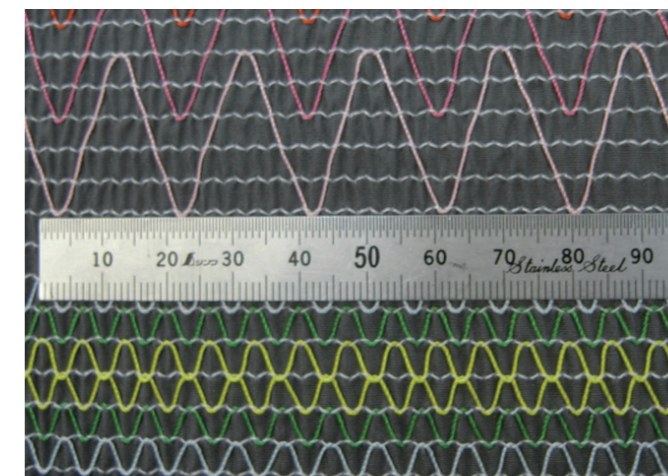
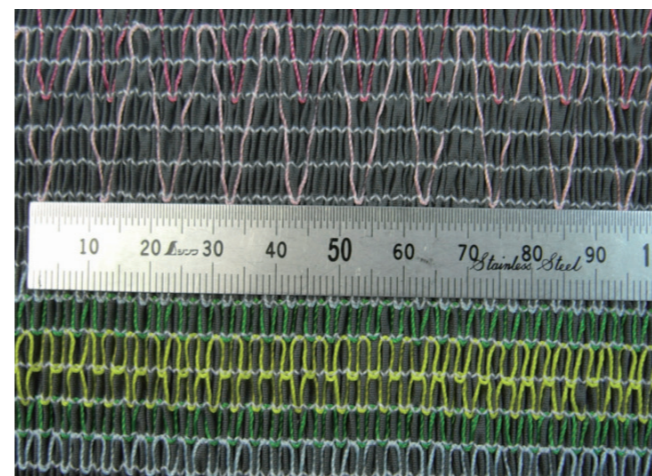

● PQで縫製した製品は強度もあり単環(10-ET)、二重環(ET)よりも伸縮性があります。

The products sewn by PQ are stronger and more stretchable than by Single chain (10-ET) and Double chain stitch (ET).

Los productos que en cosido por PQ es más fuerte y más stretchable que la Sola cadena (10-ET) y cadena Doble puntada (ET).

使用PQ縫制出来的产品既有单环的强度，又有二重环的伸缩性。

MODEL	No. of Needle	No. of Thread	Needle Type		Gauge (Inch)	No. of Stitch (Stitch/Inch)	Diff. Feed Ratio	Presser Foot Lift (mm)	Needle Bar Stroke (mm)	Max. Speed (rpm)
			Organ (#)	Schmetz (Nm)						
NB1433PQ-SM	33	132	DV×57 14	DV×57 90	3/16	4~18	—	6	34	2000

PSSMカムデザイン

CAM DESIGN FOR PSSM / PLAN DE LA LEVA PARA PSSM / 打褶打摺用模様盤

■ 標準カムデザイン (NO.1~9)
STANDARD CAM DESIGN (NO.1~9)

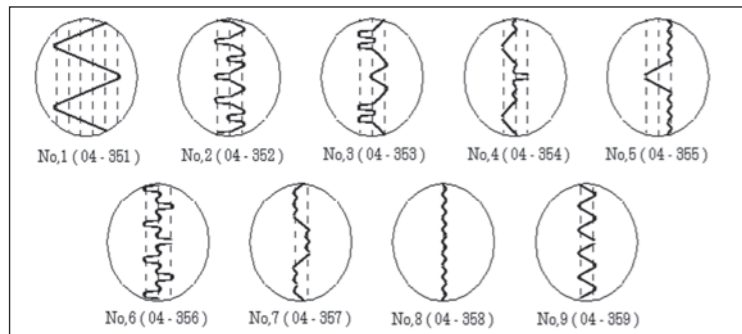

■ オプションカムデザイン
OPTIONAL CAM DESIGN

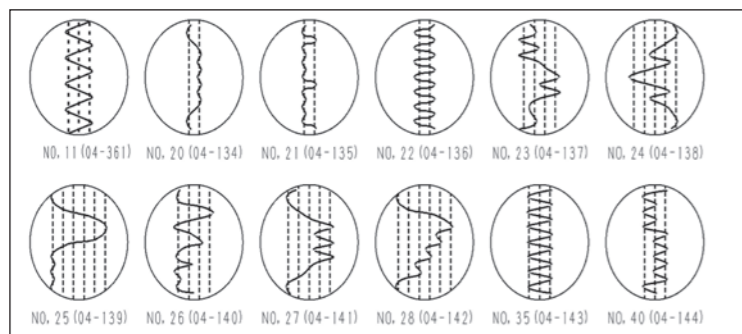

BX, NB SERIES TECHNICAL DATA 仕様詳細

MODEL	No. of Needle	No. of Thread	Needle Type		Gauge (Inch)	No. of Stitch (Stitch/Inch)		Presser Foot Lift (mm)	Needle Bar Stroke (mm)	Max. Speed (rpm)	
			Organ (#)	Schmetz (Nm)		BX	NB				
BX1425P	NB1425P	25	50	DV×57 14	DV×57 90	1/4	8~16	4~18	10	34	2500
BX1425PS	NB1425PS	25	50	DV×57 14	DV×57 90	1/4	7~17	4~18	10	34	2500
BX1425PSSM	NB1425PSSM	25	75	DV×57 14	DV×57 90	1/4	7~17	4~18	BX-6 NB-8	34	2000
BX1433P	NB1433P	33	66	DV×57 14	DV×57 90	3/16	7~17	4~18	10	34	2500
BX1433PS	NB1433PS	33	66	DV×57 14	DV×57 90	3/16	7~17	4~18	10	34	2500
BX1433PSSM	NB1433PSSM	33	99	DV×57 14	DV×57 90	3/16	7~17	4~18	BX-6 NB-8	34	2000
BX1025P	NB1025P	25	25	DV×57LE 21		1/4	7~17	4~18	10	34	2500
BX1025PS	NB1025PS	25	25	DV×57LE 21		1/4	7~17	4~18	10	34	2500
BX1025PSSM	NB1025PSSM	25	50	DV×57LE 21		1/4	7~17	4~18	BX-6 NB-8	34	2000
BX1033P	NB1033P	33	33	DV×57LE 21		3/16	7~17	4~18	10	34	2500
BX1033PS	NB1033PS	33	33	DV×57LE 21		3/16	8~16	4~18	10	34	2500
BX1033PSSM	NB1033PSSM	33	33	DV×57LE 21		3/16	8~16	4~18	BX-6 NB-8	34	2000
BX1425PS-ET	NB1425PS-ET	25	50	DV×57 14	DV×57 90	1/4	7~17	4~18	10	34	2500
BX1425PSSM-ET	NB1425PSSM-ET	25	75	DV×57 14	DV×57 90	1/4	7~17	4~18	BX-6 NB-8	34	2000
BX1433PS-ET	NB1433PS-ET	33	66	DV×57 14	DV×57 90	3/16	7~17	4~18	10	34	2500
BX1433PSSM-ET	NB1433PSSM-ET	33	99	DV×57 14	DV×57 90	3/16	7~17	4~18	BX-6 NB-8	34	2000
BX1425PTV	NB1425PTV	25	50	DV×57 12	DV×57 80	1/4	7~17	4~18	10	34	2500
BX1433PTV	NB1433PTV	33	66	DV×57 12	DV×57 80	3/16	7~17	4~18	10	34	2500
	NB1425PQ	25	100	DV×57 14	DV×57 90	1/4		4~18	8	34	2000
	NB1433PQ	33	132	DV×57 14	DV×57 90	3/16		4~18	8	34	2000
	NB1425PQSM	25	75	DV×57 14	DV×57 90	1/4		4~18	8	34	2000
	NB1433PQSM	33	99	DV×57 14	DV×57 90	3/16		4~18	8	34	2000

NB シリーズの糸立てセットアップ方法

HOW TO SET UP THREAD STAND OF NB SERIES / COMO PONER PORTA-HILO DE SERIE NB / NB系列线架的安装方法

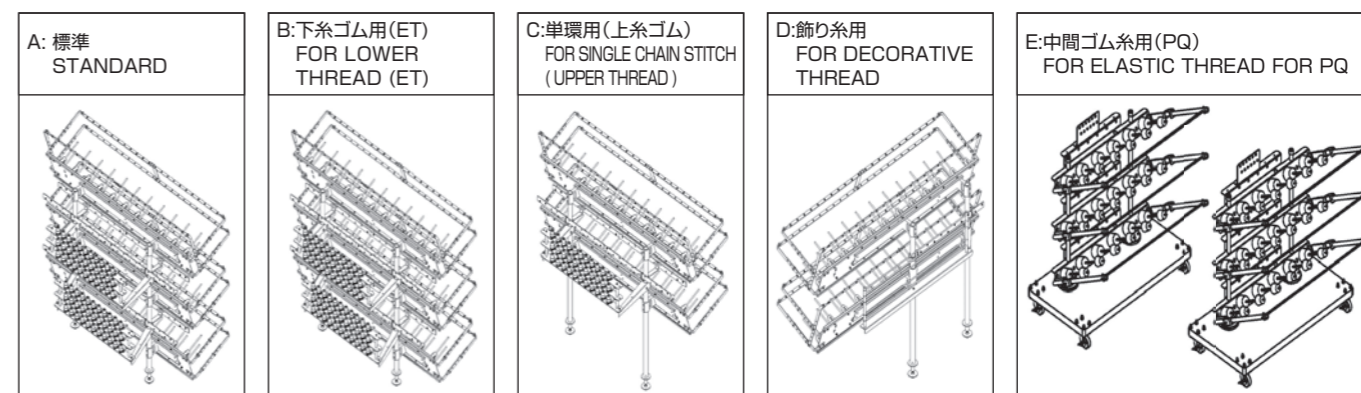
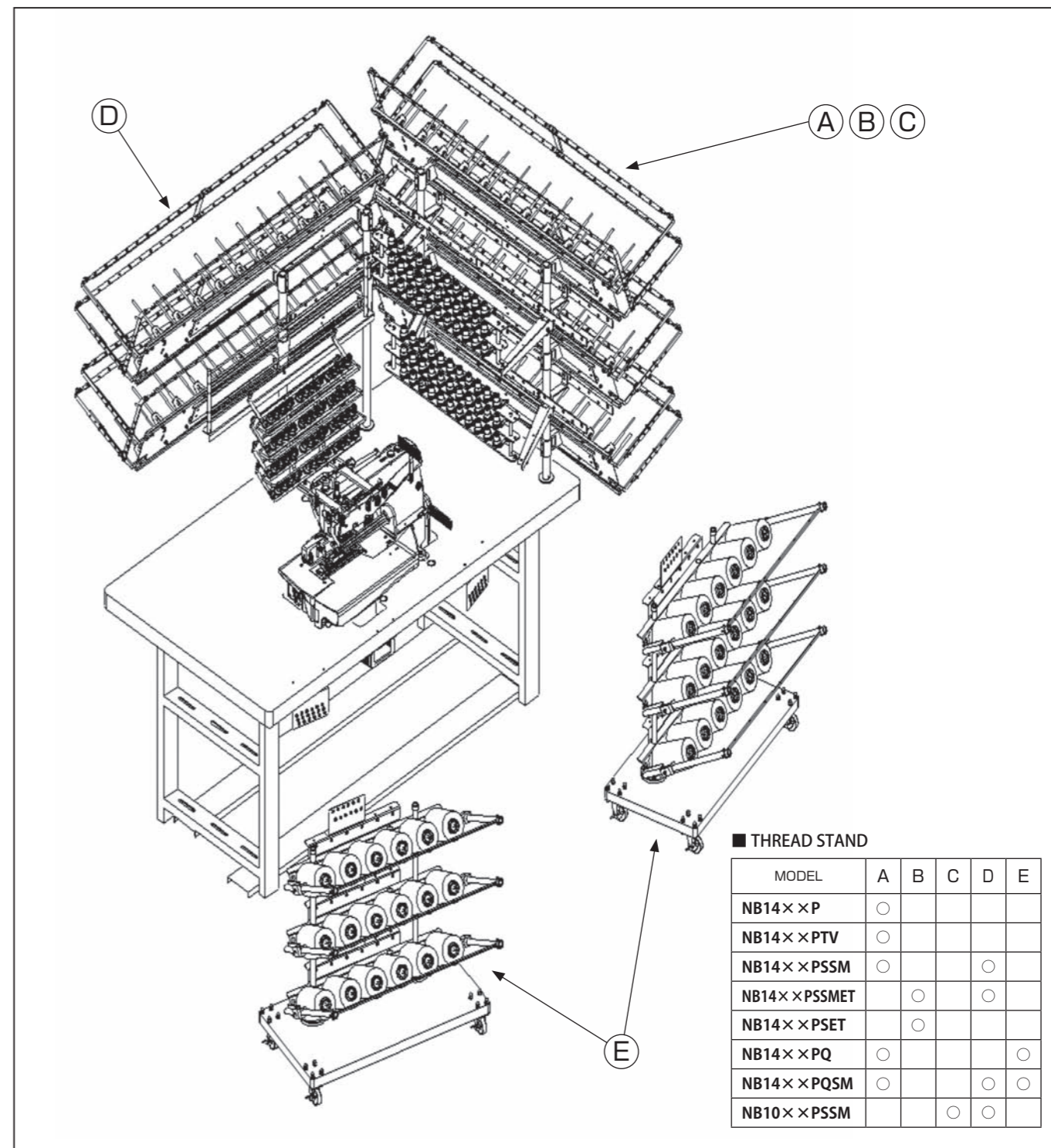

FX SERIES

FXシリーズは、シリンダーベッド、4～21本針、ルーパー縦振りの高速二重環縫いマシンです。トレーニングウェア、パジャマ、トランクス、スウェットパンツなどのゴム付けからライン付けまで種々の用途に応用できます。ゴム張り装置、エア式開閉フォルダ、糸切り装置もサブモデル、オプションとしてご利用いただけます。またエア式糸切り装置は当社独自の設計による機構で、二つのシリンダーを用いており、確実に糸をカットし、糸残りも非常に短く生産性を大幅に向上させます。またシリンダーベッドの外径は420mmで、子供服などの丸ゴム付けも行えます。

FX series is a versatile multi-needle, cylinder bed, double chain stitch machine with vertical looper movement mechanism. It can be used for attaching elastic and line tape to sweat pants, pajamas, trunks and similar garments. Major features of this series are the wide range of available gauge size (4~21 needle), cylinder bed (420mm in circumference), elastic guide rollers and KANSAI SPECIAL's original rear puller mechanism. These features make this series popular for attaching pre-closed elastic. KANSAI SPECIAL's unique automatic thread cutter (UTC) increases productivity by trimming threads accurately and leaving less thread, which curtail the production cost.

Multiaguja(4-21) cama cilíndrica alta velocidad doble cadenata. Con movimiento del garfio vertical, se puede usar para unir elástico y cinta, en ropa atlética, de dormir, expandidor de elástico, guía de aire para folder, y automático corta-hilos, también están disponibles en subclass y opciones. Kansai Special automático corta-hilos, aumenta la productividad, usando 2 cilindros de aire, cortando el hilo con exactitud, mientras mantiene el resto del hilo corto, circunferencia(420mm).

FX 系列是半筒式4针~21针,弯针纵向运动高速双重环缝纫机。各种服装的上松紧,滚条等。松紧张力器,气动开闭卷边器,自动切线等分型号,附属装置可供利用。独自设计的自动切线装置,确保切线和线残头很短。提高生产率。筒形外周长420mm,童装及上环状松紧变得很容易操作。

FXモデルシリーズ 表示方法

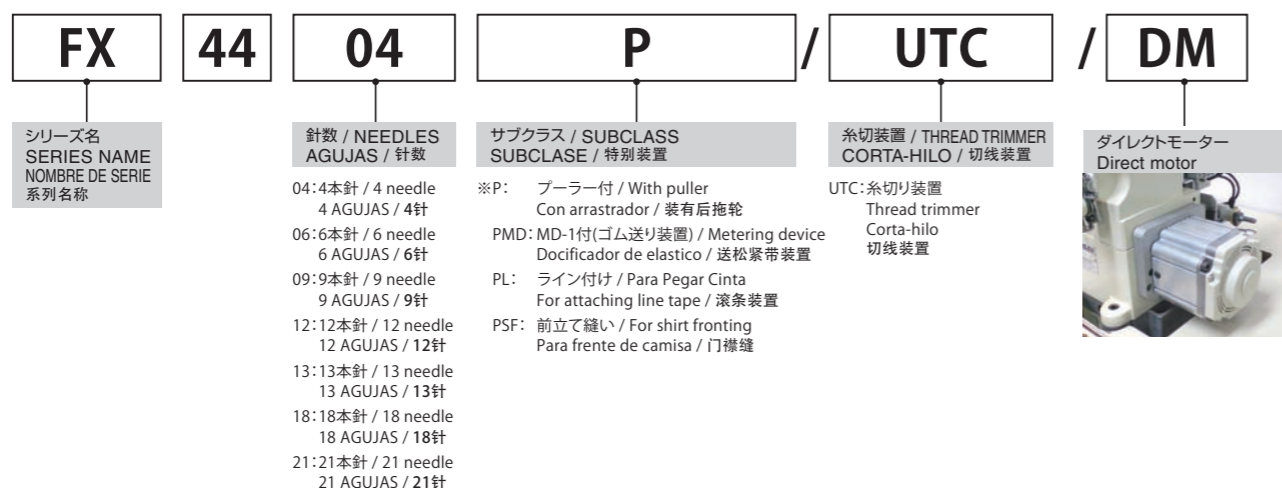

FX4404P FX4404PMD

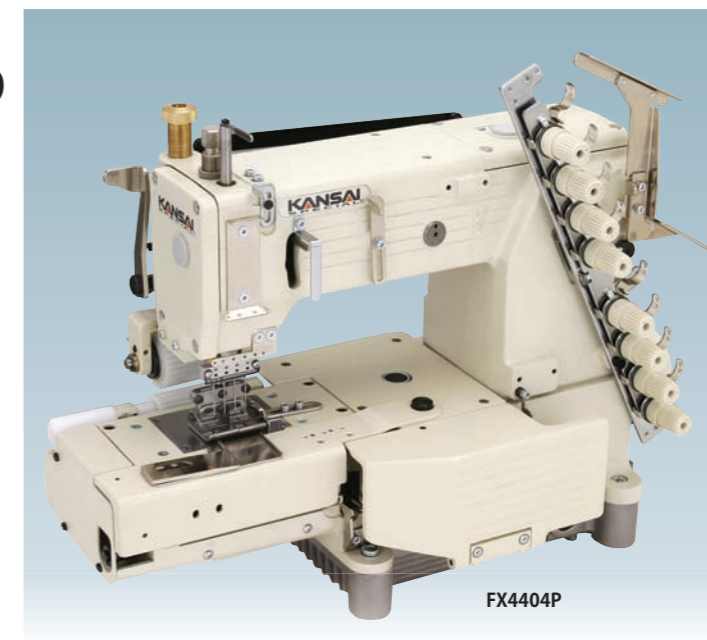
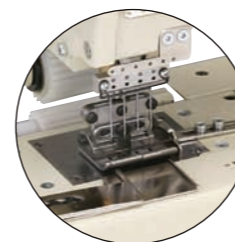

4本針二重環縫いシリンダーベッド、丸ゴム付け用マシン

4 needle, cylinder bed, double chain stitch machine for attaching pre-closed elastic.

Camá cilíndrica de 4 agujas, para pegar elástico en prendas pre-cosidas.

4 针两重环缝筒式缝纫机

FX4404PMD (with metering device)

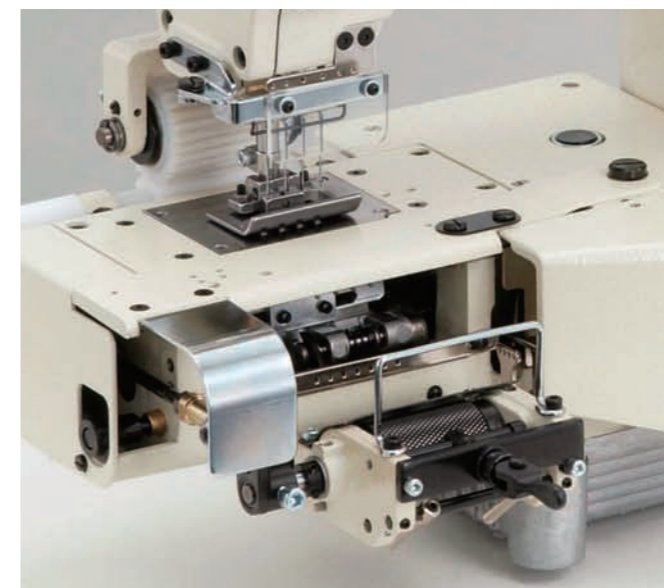

MODEL	No. of Needle	No. of Thread	Needle Type		Gauge (Inch)	No. of Stitch (Stitch/Inch)	Diff. Feed Ratio	Presser Foot Lift (mm)	Needle Bar Stroke (mm)	Max. Speed (rpm)
			Organ (#)	Schmetz (Nm)						
FX4404P	4	8	DV×57 14	DV×57 90	1, 3/4, 1-1/8, 1-1/4, 1-1/2	7~17		8	34.5	4500
FX4406P	6	12	DV×57 14	DV×57 90	1/4	7~17		8	34.5	4500
FX4408P	8	16	DV×57 14	DV×57 90	1/4	7~17		8	34.5	4500
FX4409P	9	18	DV×57 14	DV×57 90	1/4	7~17		8	34.5	4000
FX4412P	12	24	DV×57 14	DV×57 90	1/4, 5mm, 3/16	7~17		8	34.5	4000
FX4404PMD	4	8	DV×57 14	DV×57 90	1, 3/4, 1-1/8, 1-1/4, 1-1/2	7~17		8	34.5	4500
FX4406PMD	6	12	DV×57 14	DV×57 90	1/4	7~17		8	34.5	4500
FX4409PMD	9	18	DV×57 14	DV×57 90	1/4	7~17		8	34.5	4000
FX4412PMD	12	24	DV×57 14	DV×57 90	3/16, 1/4, 5mm	7~17		8	34.5	4000

FX4406PL



6本針二重環縫いシリンダーベッド、ラインテープ付け用マシン
 6 needle, cylinder bed, double chain stitch machine for attaching line tapes.
 6 agujas para pegar lineas de cinta.
 6 针两重环缝筒式，滚条带用缝纫机

MODEL	No. of Needle	No. of Thread	Needle Type		Gauge (Inch)	No. of Stitch (Stitch/Inch)	Diff. Feed Ratio	Presser Foot Lift (mm)	Needle Bar Stroke (mm)	Max. Speed (rpm)
			Organ (#)	Schmetz (Nm)						
FX4406PL	6	12	DV×57 14	DV×57 90	1/4, 1/3	7~17		8	34.5	4500
FX4408PL	8	16	DV×57 14	DV×57 90	1/4	7~17		8	34.5	4000
FX4412PL	12	24	DV×57 14	DV×57 90	1/4	7~17		8	34.5	4000

FX4404PSF

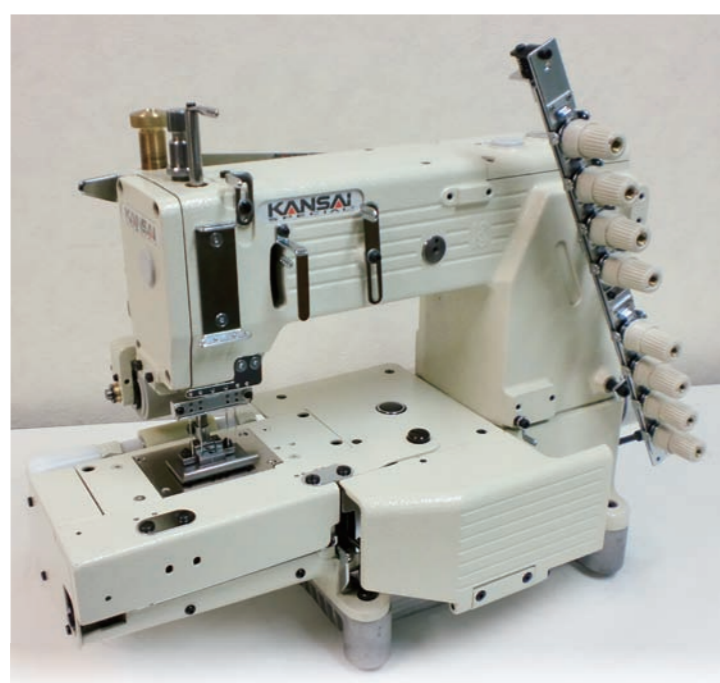

4本針シリンダーベッド、シャツの前立て用マシン
 4 needle, cylinder bed machine with smooth puller for shirt fronting.
 4 agujas, maquina de cama de cilindro con puller liso por camisa afrontar
 4 针两重环缝筒式，门襟用缝纫机（由于有前导式松紧带拉料装置，适合缝衬衫的前身片）

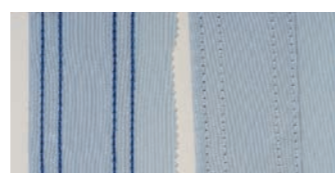
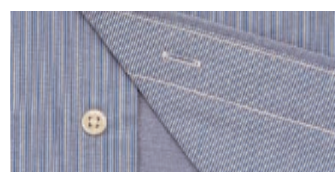

MODEL	No. of Needle	No. of Thread	Needle Type		Gauge (Inch)	No. of Stitch (Stitch/Inch)	Diff. Feed Ratio	Presser Foot Lift (mm)	Needle Bar Stroke (mm)	Max. Speed (rpm)
			Organ (#)	Schmetz (Nm)						
FX4404PSF	4	8	DV×57 14	DV×57 90	1/4-3/4-1/4 1/4-1-1/4	7~17		8	34.5	4500

FX4404P-UTC

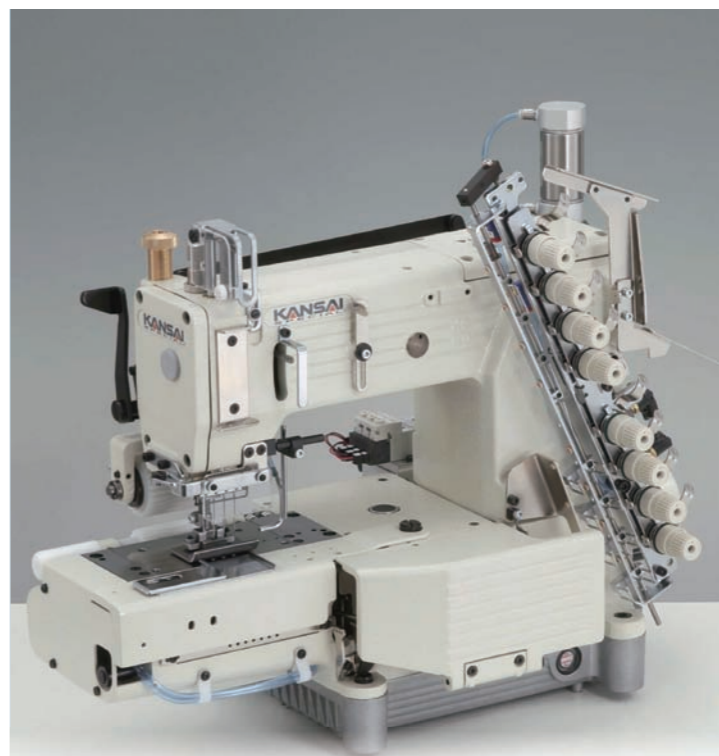
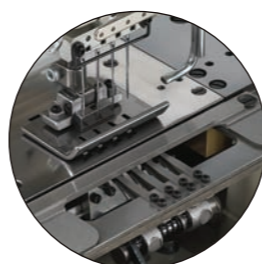

FX4412P-UTC

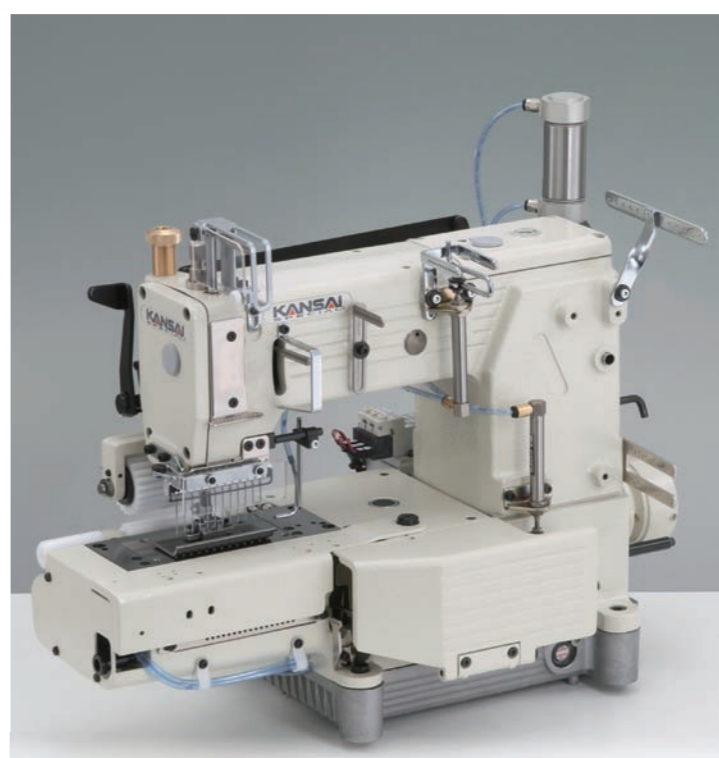

MODEL	No. of Needle	No. of Thread	Needle Type		Gauge (Inch)	No. of Stitch (Stitch/Inch)	Diff. Feed Ratio	Presser Foot Lift (mm)	Needle Bar Stroke (mm)	Max. Speed (rpm)
			Organ (#)	Schmetz (Nm)						
FX4404PUTC	4	8	DV×57 14	DV×57 90	1, 3/4, 1-1/8, 1-1/4, 1-1/2	7~17		8	34.5	4500
FX4406PUTC	6	12	DV×57 14	DV×57 90	1/4	7~17		8	34.5	4500
FX4409PUTC	9	18	DV×57 14	DV×57 90	1/4	7~17		8	34.5	4000
FX4412PUTC	12	24	DV×57 14	DV×57 90	1/4, 5mm, 3/16	7~17		8	34.5	4000

4本針二重環縫いシリンダー丸ゴム付け用自動糸切り装置付マシン
 4 needle, cylinder bed, double chain stitch machine for attaching pre-closed elastic, with pneumatic thread trimmer.

Cama cilindrica de 4 agujas, para pegar elastico en prendas precosidas, corta hilo automaticamente

4 针双重环缝，筒式带自动剪线缝纫机



RT-1

12本針二重環縫いシリンダー丸ゴム付け用自動糸切り装置付マシン

12 needle, cylinder bed, double chain stitch machine for attaching pre-closed elastic with pneumatic thread trimmer.

Cama cilindrica de 12 agujas para pegar elastico en prendas precosidas, corta hilo automaticamente.

12 针双重环缝，筒式带自动剪线缝纫机



RT-1

DX9900-4U

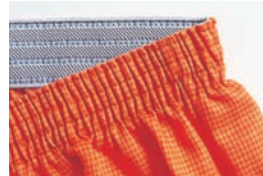

4本針二重環縫いシリンダーベッドゴム付用マシン

4 needle, cylinder bed, double chain stitch machine for attaching elastic.

Cama cilíndrica de 4 agujas para pegar elástico.

4 针半筒式 弯针横向运动，上松紧带用缝纫机

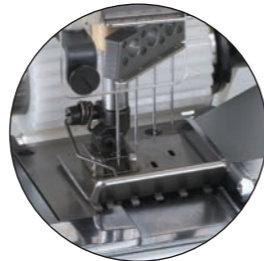

MODEL	No. of Needle	No. of Thread	Needle Type		Gauge (mm)	No. of Stitch (Stitch/Inch)	Diff. Feed Ratio	Presser Foot Lift (mm)	Needle Bar Stroke (mm)	Max. Speed (rpm)
			Organ (#)	Schmetz (Nm)						
DX9900-4U	4	8	TV×5 14	TV×5 90	6.4-6.4-6.4 8.5-8.5-8.5 9.5-9.5-9.5	7~16		8	33	4500
DX9900-4U/UTC	4	8	TV×5 14	TV×5 90	6.4-6.4-6.4 8.5-8.5-8.5 9.5-9.5-9.5	7~16		8	33	4500

DX9902-3U

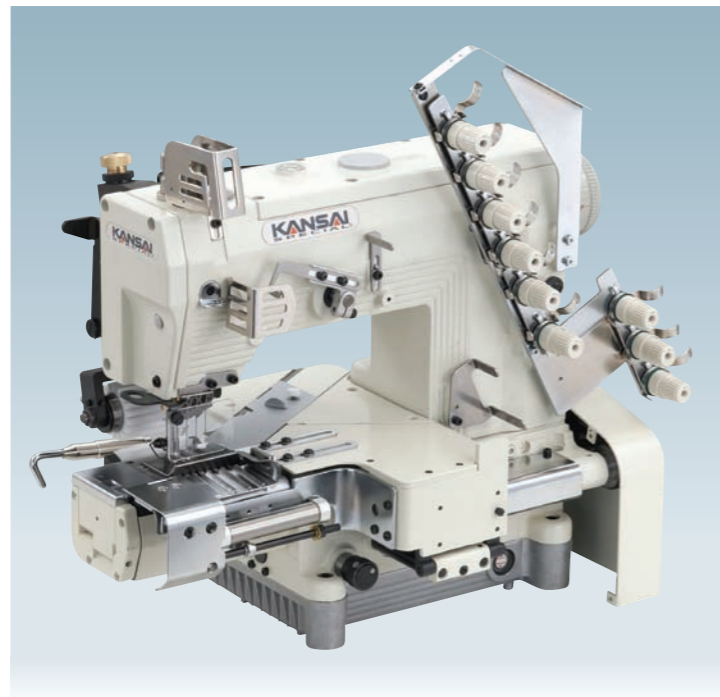

2本針下面飾り+3本針二重環縫いシリンダーベッドゴム付け用マシン

2 needle for bottom cover stitch, and 3 needle for double chain stitch, cylinder bed for attaching elastic.

2 agujas para recubridor inferior e 3 agujas para doble cadeneta, cama cilíndrica para pegar elástico.

筒式 2 针下面绷缝线迹，和 3 针锁链底缝纫机



MODEL	No. of Needle	No. of Thread	Needle Type		Gauge (mm)	No. of Stitch (Stitch/Inch)	Diff. Feed Ratio	Presser Foot Lift (mm)	Needle Bar Stroke (mm)	Max. Speed (rpm)
			Organ (#)	Schmetz (Nm)						
DX9902-3ULK	5	9	TV×5 12	TV×5 80	4.8-10-10-10(mm) 5-13-13-13	7~16		8	33	4000
DX9902-3ULK-UTC-A	5	9	TV×5 12	TV×5 80	4.8-10-10-10(mm) 5-13-13-13	7~16		8	33	4000

DX9904U

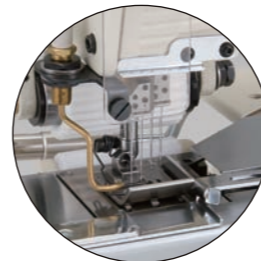
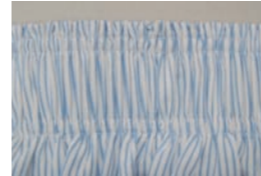

4本針シリンダーベッド二重環縫いゴム付け用マシン。
2列の偏平縫いができます。

4 needle, cylinder bed, double chain stitch machine for attaching elastic creating 2 lines of flat lock.

Cama cilíndrica de 4 agujas, 2 líneas de recubridor inferior para pegar elástico.

4 针 6 线双重环缝，上腰部分的松紧带缝纫机

■ 男性用下着のゴム付けに最適

Suitable for attaching elastic operation with double flatlock seams on men's underwear.
Adecuado para unir elástico con doble recubridor inferior en ropa interior de hombre.
适合用男性的内裤

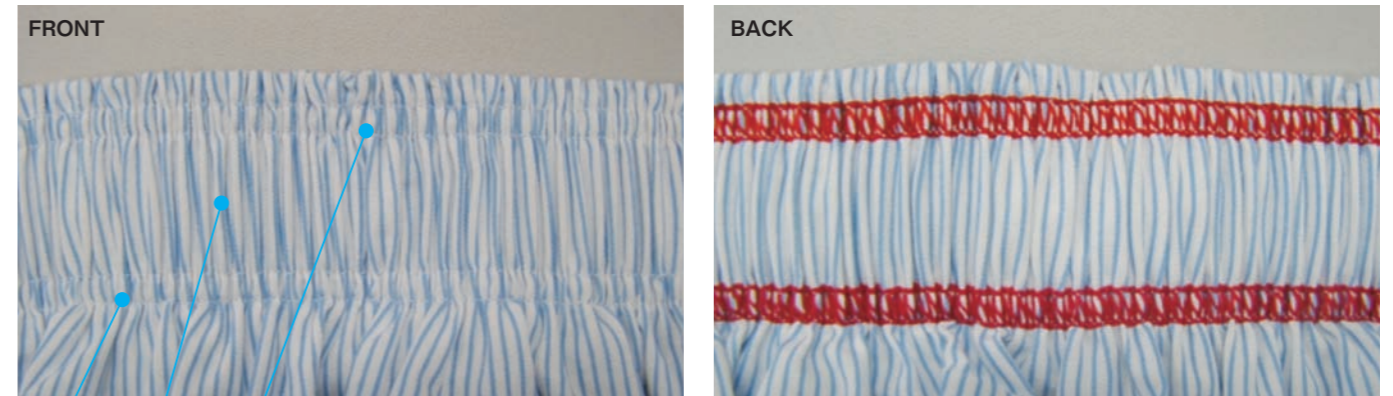

5mm 9mm 5mm
5.6mm 13mm 5.6mm
5mm 19mm 5mm
5mm 24mm 5mm

■ 2列の 2本針の下面飾り縫いを一度で縫製できます。また2列の間隔も均等に仕上げることができます。

2 lines of 2needle bottom cover stitch seam in one operation with equal distance between the two cover stitch seams.

2 líneas de 2 agujas recubridor inferior a una operación. También, la distancia entre puntada de recubridor es igual.

2 列双针加下装饰缝，可一遍完成。

MODEL	No. of Needle	No. of Thread	Needle Type		Gauge (mm)	No. of Stitch (Stitch/Inch)	Diff. Feed Ratio	Presser Foot Lift (mm)	Needle Bar Stroke (mm)	Max. Speed (rpm)
			Organ (#)	Schmetz (Nm)						
DX9904U	4	6	TV×5 14	TV×5 90	5-9-5 5-19-5	7~16	—	8	33	4500
DX9904U/UTC	4	6	TV×5 14	TV×5 90	5-9-5 5-19-5	7~16	—	8	33	4500

FBX SERIES

FBXシリーズは、ジーンズ、作業服など中厚から厚物まで幅広く縫える腰帯付け用シリンダーベッド型針送り二重環縫いマシンです。更にプラー機構をオプションで装備することができます。また、針送り下送りが連動式ですので、プッシュボタンで送り目を変えるときも同時に送り量の変更ができます。従来の縫いスレやパッカリング、厚物縫製のスリッパなども針送りにより問題なく縫うことが可能です。縦振りルーバー機構により糸も通しやすく、またシリンダーベッドですので、腰帯付け以外の丸物、ゴム入れ、前立てなど最大70mmまでの幅広い用途に使用できます。

FBX series is a cylinder bed, 2-6 needle double chain stitch machine with needle feed. It is designed for sewing waistbands of medium heavy to heavy material such as jeans and working pants. As needle feed and lower feed are linked, both feeding amounts can be adjusted at the same time by push button operation. An additional rear puller is available as option. The needle feed solves any problems, such as twisting, puckering and slipping of the material. FBX series has a wide range of applications as it can sew material up to a width of 70mm, especially tubular goods such as waistbands, elastic attaching, sewing shirts fronts and more.

FBX series cama cilindrica con transportador de agujas 2-6 agujas, puntada de doble cadeneta para coser cinturas de material de mediano a pesado, como jeans, o pantalones de trabajo. El puler es opcional. El transportador de agujas y el alimentador inferior, estan conectados, de esta manera la cantidad de alimentacion, se puede ajustar al mismo tiempo, presionando el boton. El transportador de agujas resuelve problemas tales como torcida de material deslizamiento de material pesado, cuando se esta cosiendo, etc.

FBX 系列为筒式设计针送布从2~6针双链式的缝纫机，广泛应用于缝制从中厚料到厚重料的牛仔、工作服等的腰部或裤头，还可广泛应用于需上松紧带的地方，也可用于上门襟等等，针位宽度最大70mm，加装各种装置用途更广。该系列机型因采用针送布机构和下送布机构的联动设计，所以通过按钮式调整缝迹长度可同步调整针和送布牙的送布量，这样就完全解决产品的变形、错位、打褶或鱼尾纹等现象，达到产品平整的效果；该机型弯针为纵向摆动，穿线更简单容易；备有后拖轮装置可选购。

FBXシリーズ 表示方法

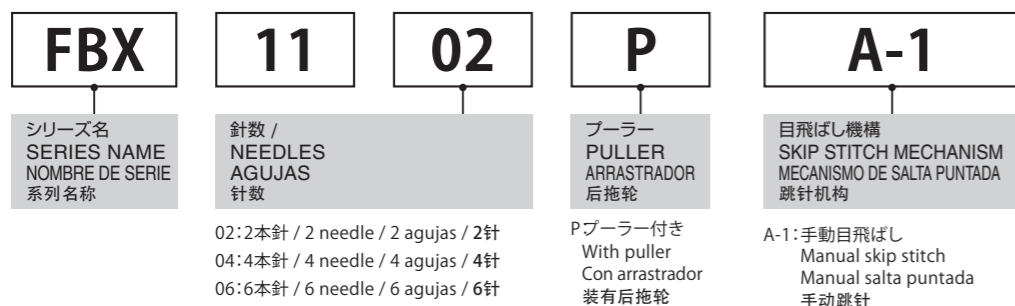

FBX自動機シリーズ モデル表示方法

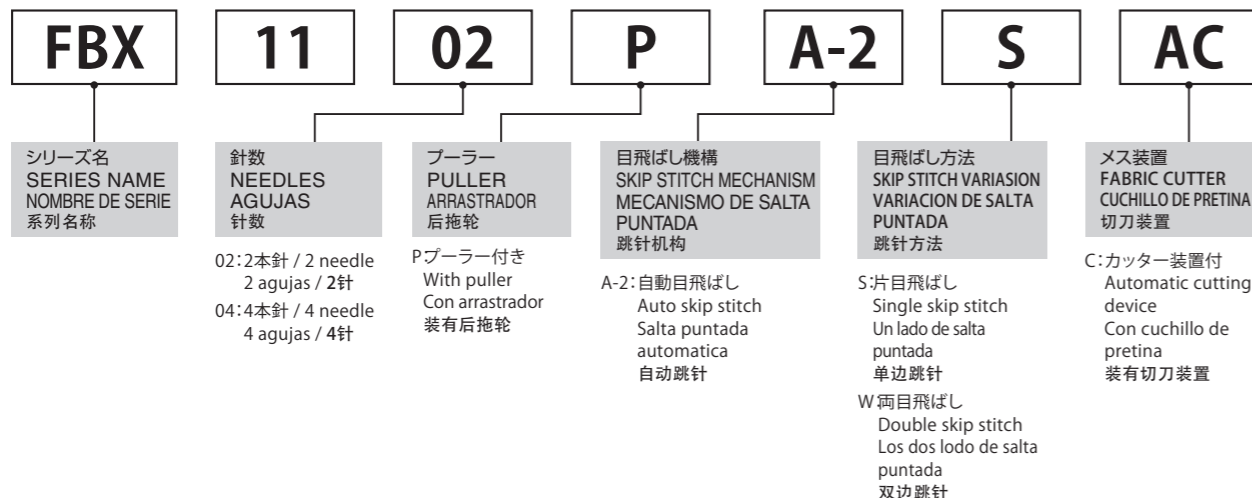

FBX1102YS

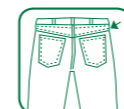

2本針、シリンダーベッド針送りマシン。
ヨークシームマシン

2 needle cylinder bed machine especially designed for the yoke seam. Available with various different gauge sizes.

2 aguja de la maquina cilindrica especialmente disenado para la costura de Yoke. Disponible con diferentes tamanos de calibre.

2 针针杆送布缝纫机

MODEL	No. of Needle	No. of Thread	Needle Type		Gauge (Inch)	No. of Stitch (Stitch/Inch)	Diff. Feed Ratio	Presser Foot Lift (mm)	NeedleBar Stroke (mm)	Max. Speed (rpm)
			Organ (#)	Schmetz (Nm)						
FBX1102YS	2	4	DV X57 21 (#14~25)	DV X 57 130 (#90~200)	1/4",9/32",3/8"	4~12		9	32	4000

FBX1104P FBX1106P

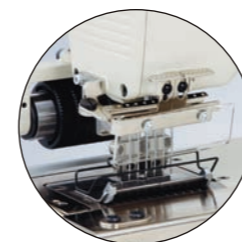

FBX1106P



4~6本針 シリンダーベッド針送りマシン。
最大針幅70mm。

4 and 6 needle, cylinder bed needle feed machine with wide range of available gauge sizes. Needle space up to 70mm. Total needle width up to 70mm

Maquina de cama cilindrica 4~6 agujas doble cadeneta con alimentador de agujas para varias aplicaciones, con espacio de 70mm.

4~6 针针杆送布缝纫机



MODEL	No. of Needle	No. of Thread	Needle Type		Gauge (Inch)	No. of Stitch (Stitch/Inch)	Diff. Feed Ratio	Presser Foot Lift (mm)	NeedleBar Stroke (mm)	Max. Speed (rpm)
			Organ (#)	Schmetz (Nm)						
FBX1104P	4	8	DV X57 21 (#18~25)	DV X 57 130 (#110~200)	1/4-1-1/4,1/4-7/8-1/4	4~12 (2.1~6.4mm)		9	32	4000
FBX-1106P	12 ※(6)	12	DV X57 21 (#14~25)	DV X 57 130 (#90~200)	1/4"	4~12		9	32	3000

※ 12本針の中70m/m(針間隔 1/4")の内6本針が使用可能です。

Max. 6 needle application is possible to use within the total gauge width at 70mm of 12 needle.

※ Es posible utilizar maximo 6 agujas en la capacidad de 70 mm de 12 agujas (1/4" entre agujas).

12 针的总针距是 70m/m, 针间距是 1/4, 也可以作为 6 针使用

FBX1102PA-1



FRONT BACK

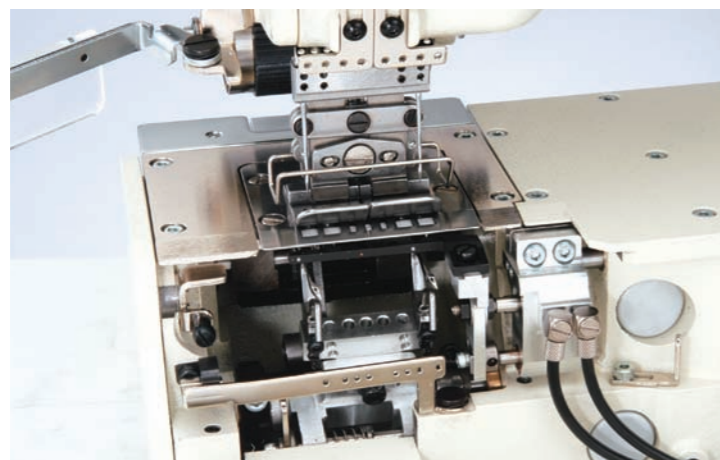

2~4本針 シリンダーベッド針送りマシン。
目飛ばし機構付き。

2 to 4 needle machine with manual
skip stitch device.

Maquina de cama cilindrica 2~4
aguas doble cadeneta con
alimentador de agujas para brincar
puntada.

2 ~ 4 针杆送布

MODEL	No. of Needle	No. of Thread	Needle Type		Gauge (Inch)	No. of Stitch (Stitch/Inch)	Diff. Feed Ratio	Presser Foot Lift (mm)	Needle Bar Stroke (mm)	Max. Speed (rpm)
			Organ (#)	Schmetz (Nm)						
FBX1102PA-1	2	4	DV X 57 21 (#14~25)	DV X 57 130 (#90~200)	1-1/2, 1-3/8, 1-1/4	4~12		9	32	4000
FBX1104PA-1	4	8	DV X 57 21 (#14~25)	DV X 57 130 (#90~200)	1/4-1-1/4, 1/4-7/8-1/4	4~12		9	32	4000

FBX1104PA-2WAC

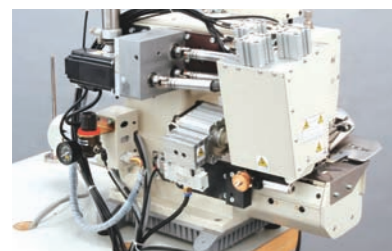

2(4)本針、針送り機構付きシリンダーベッド型腰帯付け用マシン。
ダブルプラー装置、自動目飛ばし装置、自動カッターを装備した
自動機です。

2(4) needle, cylinder bed, with needle feed
mechanism for attaching waistbands. Double puller,
skip stitch device and automatic cutting device result in
a uniform quality finish.

FBX PA-2WAC e uma maquina cilindrica,2(4)aguas
e ponto duplo com alimentacao da agulha para unir o
cos ao jeans.

Extrator duplo,mecanismo de ponto falho e cortador
automatico que resultam uma qualidade final
uniforme.A cadencia do motor sincroniza as pecas da
alimentacao,automaticamente o cos (e sem cadeia)
pode cortar e falhar os pontos que sao feitos durante
a costura do começo e no fim de acordo com a
medida requerida.Todas as funcoes sao controladas
eletricamente e facilmente programadas atraves do
painel

2(4) 针杆送布牛仔上腰二重环缝纫机，带上下拖
轮直驱式马达装置，裤腰成型后在任意自定尺寸处理，
自动操作切割装置裤腰的腰部可以任意跳线设定装置
(起到缩段工时，不用再次折线作用)所有功能通过电子
操作箱，操作起来特别方便

PA-2WAC
裤腰成型后在任意自定尺寸处理

MODEL	No. of Needle	No. of Thread	Needle Type		Gauge (Inch)	No. of Stitch (Stitch/Inch)	Diff. Feed Ratio	Presser Foot Lift (mm)	Needle Bar Stroke (mm)	Max. Speed (rpm)
			Organ (#)	Schmetz (Nm)						
FBX1102PA-2WAC	2	4	DV X 57 21 (#14~25)	DV X 57 130 (#90~200)	1-1/4, 1-3/8	4~12		9	32	4000
FBX1104PA-2WAC	4	8	DV X 57 21 (#14~25)	DV X 57 130 (#90~200)	1/4-1-1/4, 1/4-7/8-1/4	4~12		9	32	4000

FBX1102PA-2AC/LS (Lock stitch & Chain stitch)



2本針、針送りシリンダーベッド本縫い+二重環縫い自動腰帯
付けマシン。外側の針で本縫い、内側の針で二重環縫いを行
います。また生地カットおよび目飛ばしを任意のタイミングで
自動的に行います。

2 needle, cylinder bed, with needle feed
mechanism, lock stitch & double chain stitch
automatic machine for waistbands. The outside
needle is for lock stitch, the inside needle for
double chain stitch. Automatic cutting at the
beginning and the end of sewing & automatic skip
stitching device the stitch automatically.

Maquina cilindrica automatica para cinturas,con
alimentador de agujas,de dos agujas para jeans
o similares.Este unidad automatica es una clase
especial de nuestra FBX1102PA-2AC, mientras
las agujas exteriores hacen costura recta, con un
gancho rotativo y una bobina grande,las agujas
interiores hacen costura de cadeneta.

Este sistema de combinacion de costura recta y de
cadeneta,elimina problemas tales como arrugar el
material,dando un terminado nitido.Cuando se cose
continuamente
cintura,esta unidad auto-matica corta los dos
extremosk tiene funcion automatica para salto de
puntada, de tal forma que los dos extrimos quedan
sin coser.

2 针，针送筒式设计，牛仔裤等，自动缝裤腰专用机
FBX-1102PA-AC/LS 是这系列中的特等机，外侧针使用了大
的筒管的正式缝制，内侧针是双重环缝正式缝制和双重环缝
的组合实现了漂亮完成产品应为有后拉系统和送针系统提高
了生产率

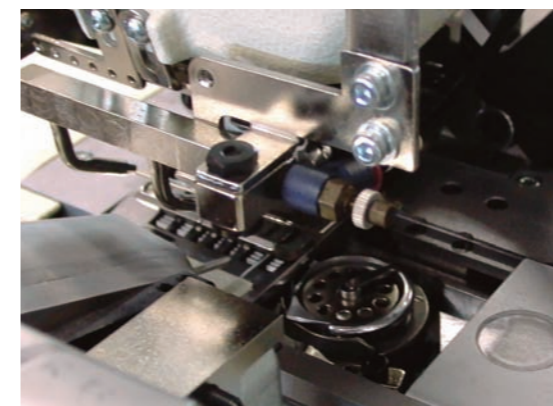

← 本縫
lock stitch / Puntada recta / 平缝线迹

← 二重環縫
chain stitch / Puntada de cadeneta / 链式线迹

MODEL	No. of Needle	No. of Thread	Needle Type		Gauge (Inch)	No. of Stitch (Stitch/Inch)	Diff. Feed Ratio	Presser Foot Lift (mm)	Needle Bar Stroke (mm)	Max. Speed (rpm)
			Organ (#)	Schmetz (Nm)						
FBX1102PA-2AC/LS	2	4	DV x 5718~25 for chain stitch, DP x 518 for lock stitch		1-1/2, 1-3/8, 1-1/4	4~12 (2.1~6.4m/m)		9	34	3000

WX・LX SERIES

WXシリーズは、フラットベッド、高速・高性能両面飾り偏平縫いミシンです。

1本針のLXから4本針のモデル(WX8842-1)まで、偏平縫いからテープ付け、かぶせ縫い、レースゴム付け、テープ取り、ポケット向布付け、シェルステッチテープ付けなど応用範囲の広いシリーズです。プッシュボタン式送り調節機構により、容易に縫い目の長さを調節することができます(最大4mm、6針/インチ)。安定した縫い調子、伸びのある美しい縫い目からあらゆるニット、メリヤス製品に最適です。

WX series is flatbed, high speed, high performance with top and bottom cover stitch that have from 1 needle (LX) to 4 needle (WX8842-1), to be applied for any type of fabric and operation like plain stitch, covering, attaching elastic lace, taping, attaching pocket facing, shell stitching plus tape binding, and so on. Stitch length can be adjusted by push bottom easily (max. 4mm, 6 stitch/inch). This series is most suitable for knit fabrics in order to achieve uniform, flexible and beautiful stitch formation.

WX series maquina de cama plana, alta velocidad con recubridor arriba y abajo, desde una aguja, modelo LX hasta cuatro agujas, modelo WX8842-1 es posible usarlo en cualquier clase de telas y operaciones, tales como puntada regular, recubrir-pegar cinta elastica, forros de bolcillo, puntada de concha y otras mas. El largo de puntada se regula facilmente aplicando precision al boton regulador(max.:4mm, 6 puntadas por pulgada). Esta serie produce una puntada bonita y uniforme en telas de punto.

WX 系列是平台式，高速、高性能两面绷缝的缝纫机。功能有一般装饰缝，滚领，花边松紧，滚条，裤袋的内衬布缝等广范围的系列缝纫机。通过按钮式调节，简易改变缝纫线迹长度<最大4mm, 6针 / 1英寸>安定的缝纫，美观的可伸缩的缝迹为针织最合适。

WXシリーズ モデル表示方法

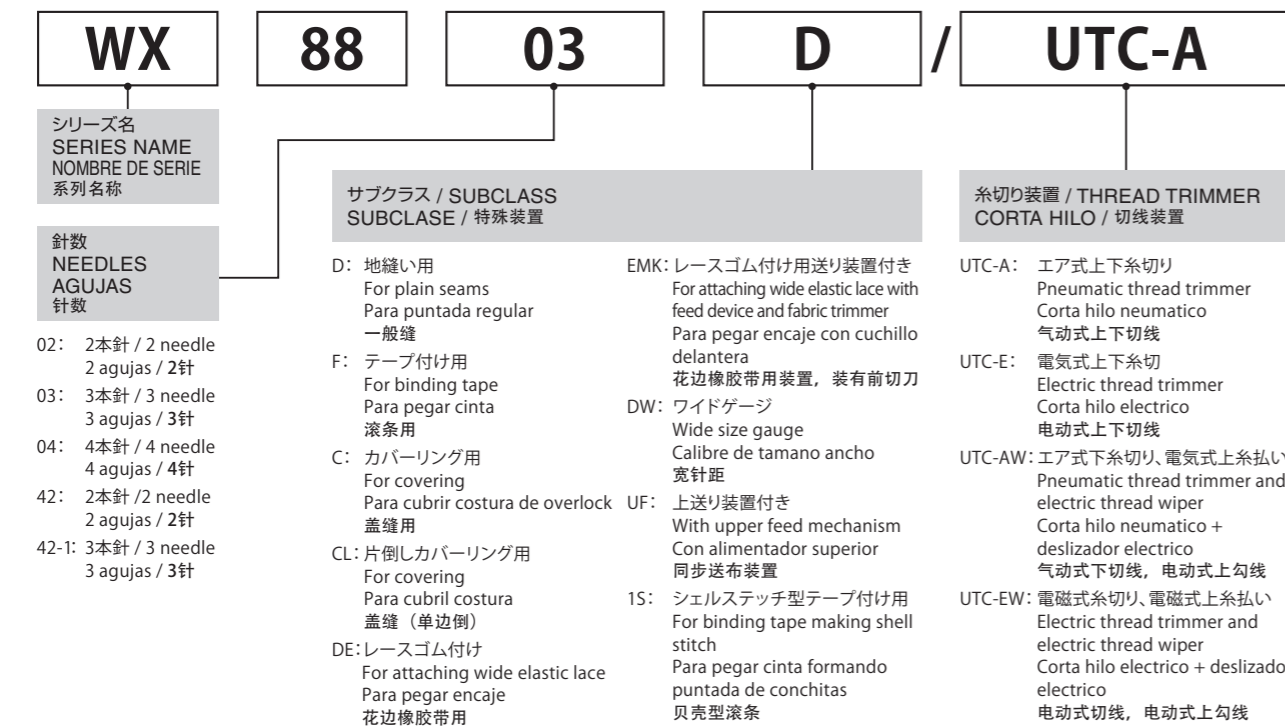

LXシリーズ モデル表示方法

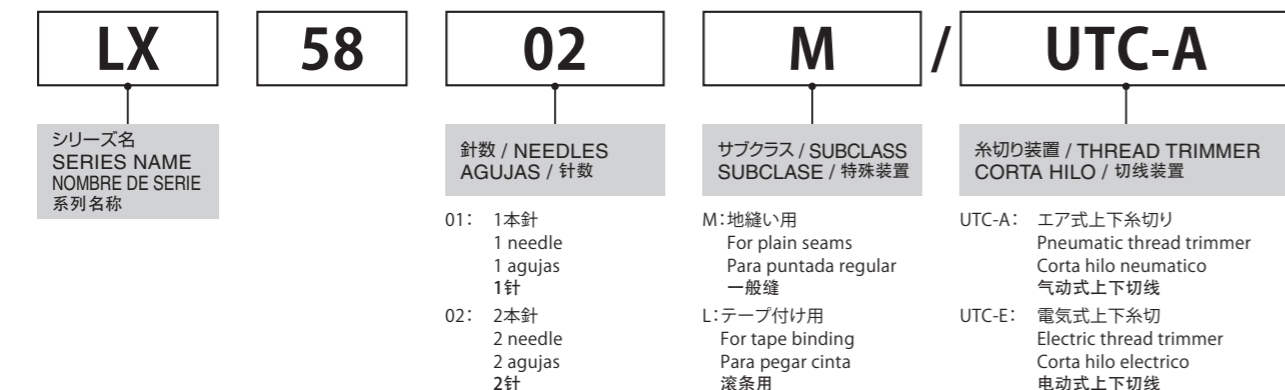

WX8803D WX8803DW

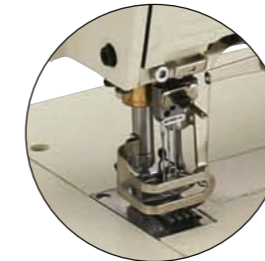

3本針両面飾り地縫いミシン

3 needle, flatbed, high speed, top and bottom cover stitch machine for plain seams.

3 agujas doble cadeneta con recubridor superior y inferior para puntada regular.

3 针两面装饰，平台式绷缝机

MODEL	No. of Needle	No. of Thread	Needle Type		Gauge (Inch)	No. of Stitch (Stitch/Inch)	Diff. Feed Ratio	Presser Foot Lift (mm)	Needle Bar Stroke (mm)	Max. Speed (rpm)
			Organ (#)	Schmetz (Nm)						
WX8802D	2	4	UYX128GAS 9~14	UYX128GAS 60~90	1/8, 5/32, 7/32, 1/4, 3/16	8~16	0.7~2	6	31	6000
WX8803D	3	5	UYX128GAS 9~14	UYX128GAS 60~90	7/32, 1/4, 3/16	8~16	0.7~2	6	31	6000
WX8803DW	3	5	UYX128GAS 9~14	UYX128GAS 60~90	7/32, 1/4	8~16	0.7~2	6	31	6000
※ WX8802D/UTC-A/E WX8802D/UTC-AW/EW	2	4	UYX128GAS 9~14	UYX128GAS 60~90	1/8, 5/32, 7/32, 1/4, 3/16	8~16	0.7~2	6	31	6000
※ WX8803D/UTC-A/E WX8803D/UTC-AW/EW	3	5	UYX128GAS 9~14	UYX128GAS 60~90	7/32, 1/4, 3/16	8~16	0.7~2	6	31	6000
※ WX8803DW/UTC-A/E WX8803DW/UTC-AW/EW	3	5	UYX128GAS 9~14	UYX128GAS 60~90	7/32, 1/4	8~16	0.7~2	6	31	6000

WX8803D-UF

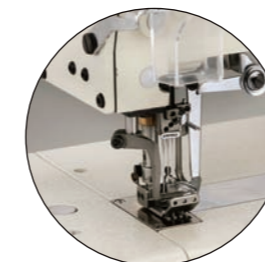

3本針両面飾り上下差動送り機構付きミシン

3 needle, flatbed, top and bottom cover stitch machine with upper feed mechanism.

3 agujas doble cadeneta con recubridor superior e inferior para puntada regular con alimentador superior.

3 针两面装饰，上下同步绷缝机

MODEL	No. of Needle	No. of Thread	Needle Type		Gauge (Inch)	No. of Stitch (Stitch/Inch)	Diff. Feed Ratio	Upper Feed Amount (mm)		Presser Foot Lift (mm)	Needle Bar Stroke (mm)	Max. Speed (rpm)
			Organ (#)	Schmetz (Nm)				↔	↑↓			
WX8802D-UF	2	4	UYX128GAS 9~14	UYX128GAS 60~90	3/16	8~16	0.7~2	1~7	3.5~6	6	33	5500
WX8803D-UF	3	5	UYX128GAS 9~14	UYX128GAS 60~90	7/32, 1/4, 3/16	8~16	0.7~2	1~7	3.5~6	6	33	5500
※ WX8802D-UF/UTC-A/E WX8802D-UF/UTC-AW/EW	2	4	UYX128GAS 9~14	UYX128GAS 60~90	3/16	8~16	0.7~2	1~7	3.5~6	6	33	5500
※ WX8803D-UF/UTC-A/E WX8803D-UF/UTC-AW/EW	3	5	UYX128GAS 9~14	UYX128GAS 60~90	7/32, 1/4, 3/16	8~16	0.7~2	1~7	3.5~6	6	33	5500

※ UTC-A/E -- UTC is available as A (Air type-Pneumatic) or E (Electric type) for machine with top cover stitch

※ UTC-AW/EW -- UTC is available as AW (Air type wiper) or EW (Electric type wiper) for machines without top cover stitch

WX8803F



3本針両面飾りテープ付け用ミシン
 3 needle, flatbed, high speed, top and bottom cover stitch machine for tape binding.
 3 agujas, para pegar cintas.
 3 针两面装饰平台式滚领缝缝机



MODEL	No. of Needle	No. of Thread	Needle Type		Gauge (Inch)	No. of Stitch (Stitch/Inch)	Diff. Feed Ratio	Presser Foot Lift (mm)	NeedleBar Stroke (mm)	Max. Speed (rpm)
			Organ (#)	Schmetz (Nm)						
WX8802F	2	4	UYX128GAS 9~14	UYX128GAS 60~90	1/8, 5/32, 7/32, 1/4, 3/16	8~16	0.7~2	6	31	6000
WX8803F	3	5	UYX128GAS 9~14	UYX128GAS 60~90	7/32, 1/4, 3/16	8~16	0.7~2	6	31	6000

WX8803F-UF



3本針両面飾り上下差動送り付テープ付け用ミシン
 3 needle, flatbed, high speed, top and bottom cover stitch machine for tape binding with upper feed mechanism.
 3 agujas con alimentador superior para pegar cinta.
 3 针两面装饰平台式上下同步滚领缝缝机



MODEL	No. of Needle	No. of Thread	Needle Type		Gauge (Inch)	No. of Stitch (Stitch/Inch)	Diff. Feed Ratio	Upper Feed Amount (mm)		Presser Foot Lift (mm)	NeedleBar Stroke (mm)	Max. Speed (rpm)
			Organ (#)	Schmetz (Nm)				←	↑			
WX8802F-UF	2	4	UYX128GAS 9~14	UYX128GAS 60~90	1/8, 3/16	8~16	0.7~2	1~7	3.5~6	6	33	5500
WX8803F-UF	3	5	UYX128GAS 9~14	UYX128GAS 60~90	7/32, 1/4, 3/16	8~16	0.7~2	1~7	3.5~6	6	33	5500

WX8803C WX8803CLW



WX8803CLW



WX8803C

3本針両面飾り片倒しカバーリング用ミシン
 3 needle, flatbed, high speed, top and bottom cover stitch machine for covering left fold of overlock seams.
 3 agujas, cama plana, recubridor superior e inferior para cubrir costura de over lock
 3 针两面装饰线迹包边缝缝机 (单面倒盖缝)



FRONT



BACK

MODEL	No. of Needle	No. of Thread	Needle Type		Gauge (Inch)	No. of Stitch (Stitch/Inch)	Diff. Feed Ratio	Presser Foot Lift (mm)	NeedleBar Stroke (mm)	Max. Speed (rpm)
			Organ (#)	Schmetz (Nm)						
WX8802C	2	4	UYX128GAS 9~14	UYX128GAS 60~90	3/16, 7/32, 1/4	8~16	0.7~2	6	31	6000
WX8803C	3	5	UYX128GAS 9~14	UYX128GAS 60~90	7/32, 1/4	8~16	0.7~2	6	31	6000
※ WX8802C/UTC-A/E WX8802C/UTC-AW/EW	2	4	UYX128GAS 9~14	UYX128GAS 60~90	3/16, 7/32, 1/4	8~16	0.7~2	6	31	6000
※ WX8803C/UTC-A/E WX8803C/UTC-AW/EW	3	5	UYX128GAS 9~14	UYX128GAS 60~90	7/32, 1/4	8~16	0.7~2	6	31	6000
WX8802CLW	2	4	UYX128GAS 9~14	UYX128GAS 60~90	3/16, 7/32, 1/4	8~16	0.7~2	6	31	6000
WX8803CLW	3	5	UYX128GAS 9~14	UYX128GAS 60~90	7/32, 1/4	8~16	0.7~2	6	31	6000
※ WX8802CLW/UTC-A/E WX8802CLW/UTC-AW/EW	2	4	UYX128GAS 9~14	UYX128GAS 60~90	3/16, 7/32, 1/4	8~16	0.7~2	6	31	6000
※ WX8803CLW/UTC-A/E WX8803CLW/UTC-AW/EW	3	5	UYX128GAS 9~14	UYX128GAS 60~90	7/32, 1/4	8~16	0.7~2	6	31	6000

※ UTC-A/E -- UTC is available as A (Air type-Pneumatic) or E (Electric type) for machine with top cover stitch

※ UTC-AW/EW -- UTC is available as AW (Air type wiper) or EW (Electric type wiper) for machines without top cover stitch

WX8803EMK



3本針両面飾り前メス付ゴム送り装置付ミシン
 3 needle, flatbed, top and bottom cover stitch machine with a fabric trimmer and elastic feeding mechanism for attaching elastic lace.

3 agujas, recubridor superior e inferior con cuchillo al frente y dosificador de elastico superior, con mecanismo para pegar encajes.

3 针两面装饰线迹缝缝机 (带前切刀, 上松紧带装置)

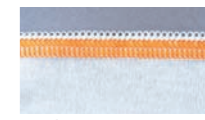

FRONT



BACK

MODEL	No. of Needle	No. of Thread	Needle Type		Gauge (Inch)	No. of Stitch (Stitch/Inch)	Diff. Feed Ratio	Presser Foot Lift (mm)	NeedleBar Stroke (mm)	Max. Speed (rpm)
			Organ (#)	Schmetz (Nm)						
WX8802EMK	2	4	UYX128GAS 9~14	UYX128GAS 60~90	3/16, 7/32, 1/4	8~16	0.7~2	5	31	5000
WX8803EMK	3	5	UYX128GAS 9~14	UYX128GAS 60~90	3/16, 7/32, 1/4	8~16	0.7~2	5	31	5000

WX8842 WX8842-1

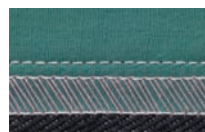

FRONT

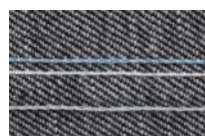

BACK



WX8842-1

ポケット向当布付用3本針上飾り縫い
ミシン安全縫い二重環付のため強度面で
優れています。

3 needle, flatbed, top cover stitch
machine with safety stitch for
attaching pocket facings.
Double chain stitch produces
durable seams .

3 agujas doble cadeneta con
recubridor superior, para pegar
forros de bolsillo.

< WX8842 >
3 针双重环缝, 2 针有上装饰缝兜部用缝纫机
< WX8842-1 >
3 针上面装饰, 缝装兜用缝纫机

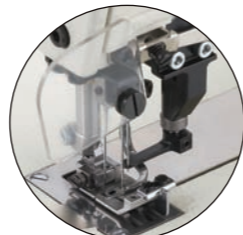

WX8842-1

MODEL	No. of Needle	No. of Thread	Needle Type		Gauge (Inch)	No. of Stitch (Stitch/Inch)	Diff. Feed Ratio	Presser Foot Lift (mm)	Needle Bar Stroke (mm)	Max. Speed (rpm)
			Organ (#)	Schmetz (Nm)						
WX8842	2	5	UYX128GAS 9~14	UYX128GAS 60~90	6.4mm	7~16	0.7~2	4.5	31	5000
WX8842-1	3	7	UYX128GAS 9~14	UYX128GAS 60~90	2.4mm×6.4mm	7~16	0.7~2	4.5	31	5000

WX8803-1S

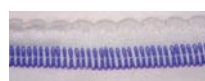

FRONT 4:1

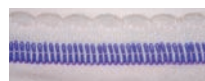

FRONT 5:1

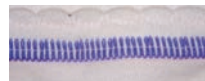

FRONT 6:1



BACK



4本針両面飾り縫いシェルステッチテー
プ取りミシン(2~4本までの下記表の
ゲージの種類があります。)また、新モデル
ではシェルの幅を3段階で調整できます

4 needle, flatbed, top and bottom cover
stitch machine for the shell (scallop)
stitching with tape binding.
3 kinds of the shell (scallop) sizes
such as small, medium and big are
adjustable.

3 y 1 agujas, recubridor superior e inferior, 1
aguja con doble, cadeneta, formando
puntada decorativa de conchitas

4 针两面装饰线迹, 贝壳缝缓胶带
(有 2 到 4 针的针位种类)
还可以贝壳缝的距离调整 3 段



MODEL	No. of Needle	No. of Thread	Needle Type		Gauge (Inch)	No. of Stitch (Stitch/Inch)	Diff. Feed Ratio	Presser Foot Lift (mm)	Needle Bar Stroke (mm)	Max. Speed (rpm)
			Organ (#)	Schmetz (Nm)						
WX8802-1S	3	6	UYX128GAS 9~14	UYX128GAS 60~90	3.5mmX4mm	8~16	0.7~2	6	31	4500
WX8803-1S	4	7	UYX128GAS 9~14	UYX128GAS 60~90	7/32×4mm	8~16	0.7~2	6	31	4500

WX8804D



4本針両面飾り縫いミシン
ブリーフの股継ぎなどフラットシーマの
代わりとしてお使い頂けます。

4 needle, flatbed, top and bottom
cover stitch machine for joining
the crotch of briefs, instead of flat
seamer.

4 agujas, cama plana, recubridor
superior e inferior para unir costuras.

4 针两面装饰, 平台式绷缝机



FRONT



BACK

MODEL	No. of Needle	No. of Thread	Needle Type		Gauge (Inch)	No. of Stitch (Stitch/Inch)	Diff. Feed Ratio	Presser Foot Lift (mm)	Needle Bar Stroke (mm)	Max. Speed (rpm)
			Organ (#)	Schmetz (Nm)						
WX8804D	4	6	SM1014H 10S		6mm, 6.4mm	8~16	0.7~2	6	30	4000
WX8804D/UTC-A/E	4	6	SM1014H 10S		6mm, 6.4mm	8~16	0.7~2	6	30	4000

LX5802LR

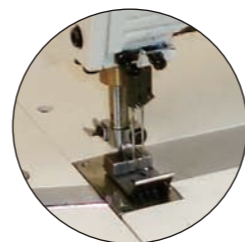

2本針二重環縫い、フラットベッド、ラッ
プシーム用押え付きミシン

2 needle, flatbed, double chain
stitch machine for lap seam with
original presser foot.

2 agujas, flatbed, la maquina de
puntada de cadena doble para
la costura del regazo con pie del
presser original.

2 针两重环缝, 平台式埋夹缝缝机
(另外配备反向埋夹缝压脚。)

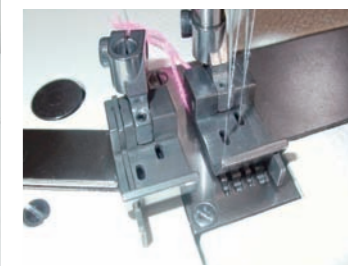

MODEL	No. of Needle	No. of Thread	Needle Type		Gauge (Inch)	No. of Stitch (Stitch/Inch)	Diff. Feed Ratio	Presser Foot Lift (mm)	Needle Bar Stroke (mm)	Max. Speed (rpm)
			Organ (#)	Schmetz (Nm)						
LX5802LR	2	4	UY128 GAS #16	UYX128 GAS 100	6.4mm	6.5~1.6		8	33	6000

LX5802L



2本針二重環縫いテープ付マシン
 2 needle, flatbed, double chain stitch machine for attaching line tapes.
 2 agujas doble cadeneta; cama plana, para pegar cintas.
 2 针双重环缝，平台式滚领缝切机



MODEL	No. of Needle	No. of Thread	Needle Type		Gauge (Inch)	No. of Stitch (Stitch/Inch)	Diff. Feed Ratio	Presser Foot Lift (mm)	Needle Bar Stroke (mm)	Max. Speed (rpm)
			Organ (#)	Schmetz (Nm)						
LX5802L	2	4	UYX128GAS 9~14	UYX128GAS 60~90	3/16, 1/4, 3/8	8~16	0.7~2	8	31	6000
LX5802M	2	4	UYX128GAS 9~14	UYX128GAS 60~90	3/16, 1/4, 3/8	8~16	0.7~2	8	31	6000

LX5802TMF



FRONT



BACK



2本針二重環縫い、タンデム針ゲージ、マジック押え付マシン
 (特殊押えにより空環をきれいに出すことができます。)
 2 needle (tandem needles), flatbed, double chain stitch machine with 'Magic Presser Foot'. (chain off can be made by the magic foot)
 2 agujas (agujas tandem) doble cadeneta (agujas en linea), cama plana.
 2 针双重环缝，平台式缝切机 (0 针位)

MODEL	No. of Needle	No. of Thread	Needle Type		Gauge (Inch)	No. of Stitch (Stitch/Inch)	Diff. Feed Ratio	Presser Foot Lift (mm)	Needle Bar Stroke (mm)	Max. Speed (rpm)
			Organ (#)	Schmetz (Nm)						
LX5802MF	2	4	UYX128GAS 9~14	UYX128GAS 60~90	2.4mm	8~16	0.7~2	8	31	6000
LX5802TMF	2	4	UYX128GAS 9~14	UYX128GAS 60~90	1/64(0.4mm)	8~16	0.7~2	8	31	6000

LX5803PHD



INDUSTRIAL SEWING MACHINES PRODUCTS GUIDE

3本針フラットベッド二重環縫いラップシーム用マシン。同梱パーツにより、逆タコ巻き縫い、1本針端縫いが可能です。
 3 needle, flatbed, double chain stitch machine for lap seaming. Includes the parts for opposite lap seaming and edge seaming.
 3 agujas, cama plana, máquina de doble cadeneta para costura de cerrar. Includo las piezas de cerradora de lado inverso, y costura de borde.
 3 针双重环缝，平台式包边缝切机

3 Operations in 1 machine / 3 funcionamientos en 1maquina / 3针双重环缝，平台式包边缝切机

1 タコ巻き縫い / LAP SEAM Cerradora / 埋夹缝

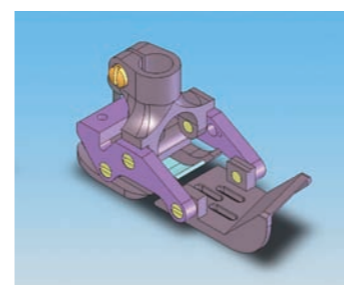

2 逆タコ巻き縫い(同梱品) / LAP SEAM IN OPPOSITE SIDE Cerradora de lado inverso / 反向埋夹缝

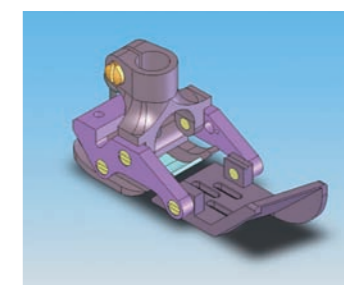

3 1本針端縫い用押え(同梱品) / Presser foot for closing the side stitch Pie para costura de borde / 1针缝端部用的压脚

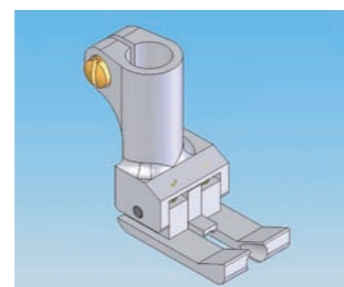

MODEL	No. of Needle	No. of Thread	Needle Type		Gauge (Inch)	No. of Stitch (Stitch/Inch)	Diff. Feed Ratio	Presser Foot Lift (mm)	Needle Bar Stroke (mm)	Max. Speed (rpm)
			Organ (#)	Schmetz (Nm)						
LX5803PHD	3	6	TVX5 18		1/2", 1/4", 3/8"	6~12	1枚送り	8	34	4500

LX5801SP

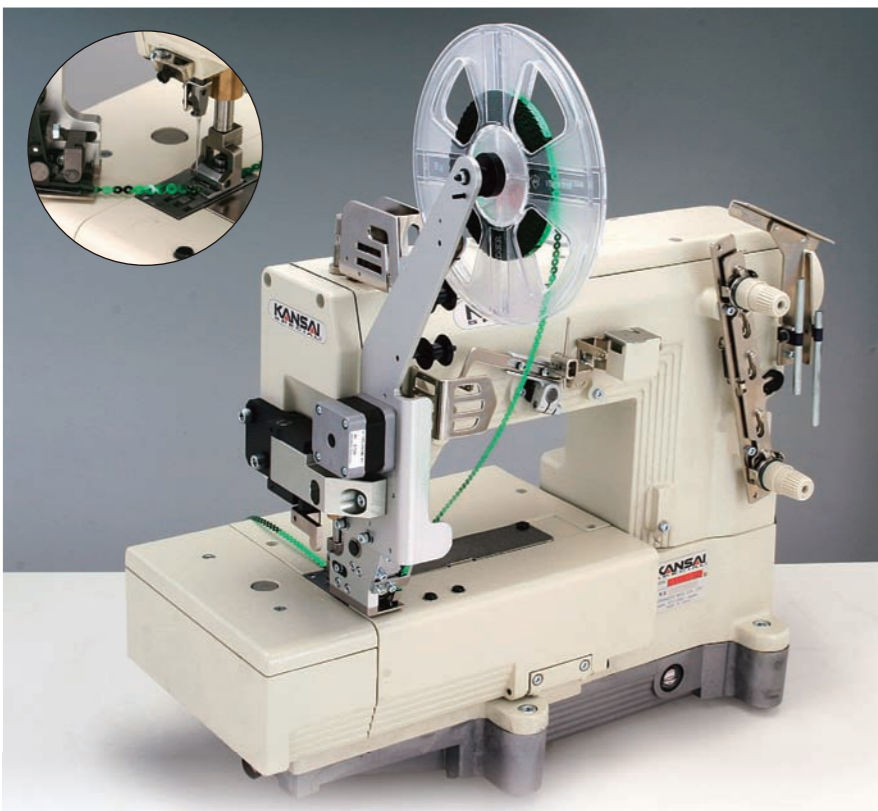

1本針二重環縫いスパンコール送り出し装置付マシン
シークインのピッチ(送り量)およびスキップ(1針毎から
10針毎に1回のシークインのスキップ縫い間隔)はパ
ルスモーター制御により操作パネルの設定で変更可能
です。ガイドを換えることで3,5,7mmのサイズのス
パンコールを使用できます。最高回転:1000rpm

1needle, flatbed, double chain stitch machine
for attaching sequins by sequin device. Sequin
size and skip timing (1 sequin every 1stitch to 10
stitches) can be changed by control box.. Three
sizes of sequin 3, 5, and 7 mm are available by
changing the optional guide and pressure foot.

1 agulha, base plana, maquina de ponto cadeia
duplo para aplicacao de cequins decorativas
atraves de um dispositivo pula pontos. O volume
da alimentacao do dispositivo e a sincronia do
pula ponto (A cada uma lantejola 1 ponto para
10 pontos) podem ser mudados atraves de uma
operacao no painel. Tres tamanhos de lantejola
podem ser usadas depois da troca da guia do
dispositivo pula ponto as de 3, 5, e de 7 mm.
Velocidade maxima: 1000 rpm

1针双重环缝, 带送装饰亮片用装置式缝纫机, 通过电
子操作控制箱的
操作设定可以改变装饰亮片间的缝制距离(装饰亮片之
间的缝制距离从1针距到10针距之间的任何距离)
通过更换卡具可以缝3, 5, 7mm尺寸的装饰亮片
最高转速:1000rpm

■ 操作パネルによる簡単な操作 / Easy setting operation panel

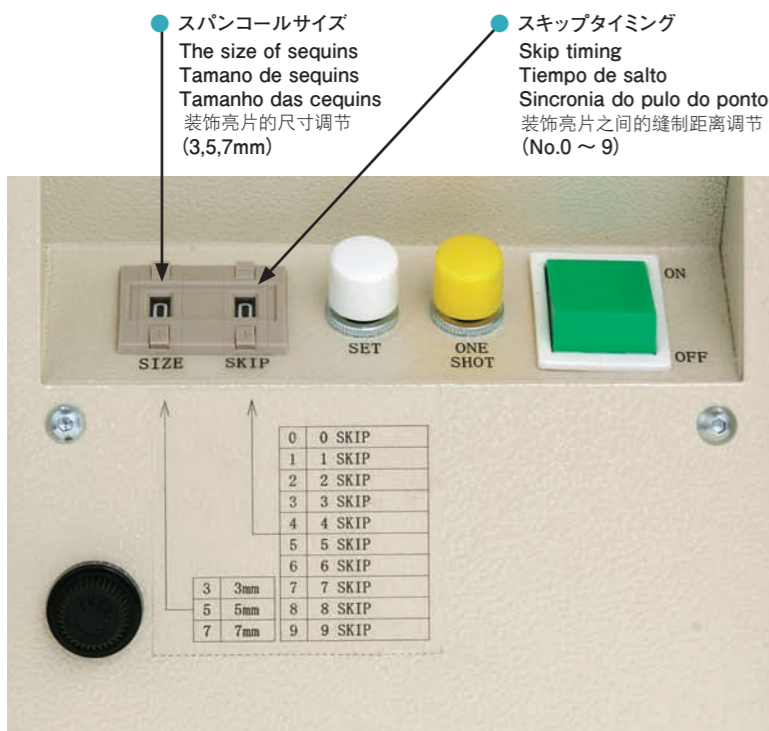

スキップタイミング / Skip timing / Tiempo de salto / Sincronia do pula ponto / 缝制样片



No.0 連続付け
1 sequin every stitch
1 cequi cada puntada
1 enfeite a cada ponto
1 针间距的缝制样片



No.1 2 ステッチに付き 1 スパンコール
1 sequin every 2 stitches
1 cequi cada 2 puntadas
1 enfeite a cada 2 pontos
2 针间距的缝制样片

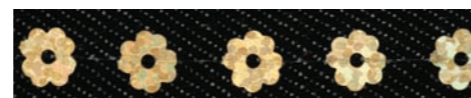

No.2 3 ステッチに付き 1 スパンコール
1 sequin every 3 stitches
1 cequi cada 3 puntadas
1 enfeite a cada 3 pontos
3 针间距的缝制样片

WX OTHER SERIES | TECHNICAL DATA 仕様詳細

MODEL	No. of Needle	No. of Thread	Needle Type		Gauge(Inch)	No. of Stitch (Stitch/Inch)	Diff. Feed Ratio	Upper Feed Amount (mm)		Presser Foot Lift (mm)	NeedleBar Stroke (mm)	Max. Speed (rpm)
			Organ (#)	Schmetz (Nm)				←→	↑↓			
WX8803-DE	3	5	UYX128GAS 9~14	UYX128GAS 60~90	7/32, 1/4	8~16	0.7~2	/	/	6	31	6000
WX8802A-UF	2	4	UYX128GAS 9~14	UYX128GAS 60~90	3/16	8~16	0.7~2	1~7	3.5~6	6	33	5500
WX8803A-UF	3	5	UYX128GAS 9~14	UYX128GAS 60~90	7/32, 1/4	8~16	0.7~2	1~7	3.5~6	6	33	5500
WX8803AH-UF	3	5	UYX128GAS 18	/	1/4	6	/	1~7	3.5~6	6	33	5000

LX OTHER SERIES | TECHNICAL DATA 仕様詳細

MODEL	No. of Needle	No. of Thread	Needle Type		Gauge(Inch)	No. of Stitch (Stitch/Inch)	Diff. Feed Ratio	Upper Feed Amount (mm)		Presser Foot Lift (mm)	NeedleBar Stroke (mm)	Max. Speed (rpm)
			Organ (#)	Schmetz (Nm)				←→	↑↓			
LX5801	1	2	UYX128GAS 9~14	UYX128GAS 60~90	/	8~16	0.7~2	/	/	8	31	6000
LX5801-UTC-A	1	2	UYX128GAS 9~14	UYX128GAS 60~90	/	8~16	0.7~2	/	/	8	31	6000
LX5801-UTC-AB	1	2	UYX128GAS 9~14	UYX128GAS 60~90	/	8~16	0.7~2	/	/	8	31	6000
LX5801-UTC-E	1	2	UYX128GAS 9~14	UYX128GAS 60~90	/	8~16	0.7~2	/	/	8	31	6000
LX5802M	2	4	UYX128GAS 9~14	UYX128GAS 60~90	1/4 (6.4mm)	8~16	0.7~2	/	/	8	31	6000

MODEL	No. of Needle	No. of Thread	Needle Type		Gauge (Inch)	No. of Stitch (Stitch/Inch)	Diff. Feed Ratio	Presser Foot Lift (mm)	NeedleBar Stroke (mm)	Max. Speed (rpm)
			Organ (#)	Schmetz (Nm)						
LX5801SP	1	2	UYX128GAS 9~14	UYX128GAS 60~90	—	8~16	0.7~2	8	31	1000

RX・REX SERIES

RXシリーズは、当社独自の設計によるセミシリンダー(外径280mm)、超高速・高性能両面飾り偏平縫いミシンです。1本針(ジーンズ裾三ツ巻き用)から4本針(RX9804D)まで、平縫い、かぶせ縫い、裾引き、ゴム付け、天ゴム付けなど、応用範囲の広いモデルです。また、用途によりプラー、右メス、左メスを装備したモデルもあります。(また、新モデルのREXは、下糸捌き機構をミシン外部に設置することにより、扱いやすさをさらに増しています。さらに5種類のゲージパーツを同梱した“MG”は、あらゆる用途に対応します。)

RX series is a high speed and high performance with top and bottom cover stitch machine of cylinder bed (circumference 280mm), which is uniquely designed by us. This series has wide range of models from 1 needle (for hemming of jeans) to 4 needle (RX9804D), and for various kinds of operations like plain stitching, covering, hemming, attaching elastic, attaching pre-closed elastic to men's briefs, and so on. Also, available for models equipped with puller, right knife, left knife, and so on. Stitch length can be adjusted by a push button easily (max. 4mm, 6 stitches/inch). A maximum sewing speed is 6000rpm, so the productivity will be upgraded. The latest line of REX that has just been introduced has the looper thread take-up cam outside of the machine for easier handling. The new subclass MG includes 5 different gauges in 1 machine for various purposes

RX series alta velocidad, con recubridor superior y inferior, cama cilíndrica (circunferencia 280mm) diseñada por nosotros. Esta serie tiene varios modelos; de una aguja para ribete jeans y de 4 agujas (RX9804D). Se puede aplicar en varios como puntada regular -para cubrir ribete, pegar elastico, adaptar elastico en prendas pre-cerradas, y otras funciones. Tambien modelos con puler y cuchillos de izquierda y derecha, longitud de puntada facilmente se ajusta por medio del boton (max. 4mm, 6 puntadas/pulgada). Velocidade maxima de coser 6000rpm. Y, nuevo modelo "REX" realiza facil mantenimiento por "Mecanismo de levanta-hilo de garfio equipado fuera de maquina". Y tambien, la subclase "MG" viene con 5 tipos de aplicaciones para multi-operacion.

RX 系列是我公司独特设计的半筒式<外周 280mm>超高速,高性能两面绷缝的缝纫机。1针<牛仔裤卷边缝>4针绷缝,盖缝,卷边,松紧带缝等广范围的系列缝纫机。另外,新款的 REX 系列是根据打线器设定在外边,在它的附近发生的问题可容易解决。而且,装有5种的针位的 MG 系列可对应各种的用途

RXシリーズ 表示方法

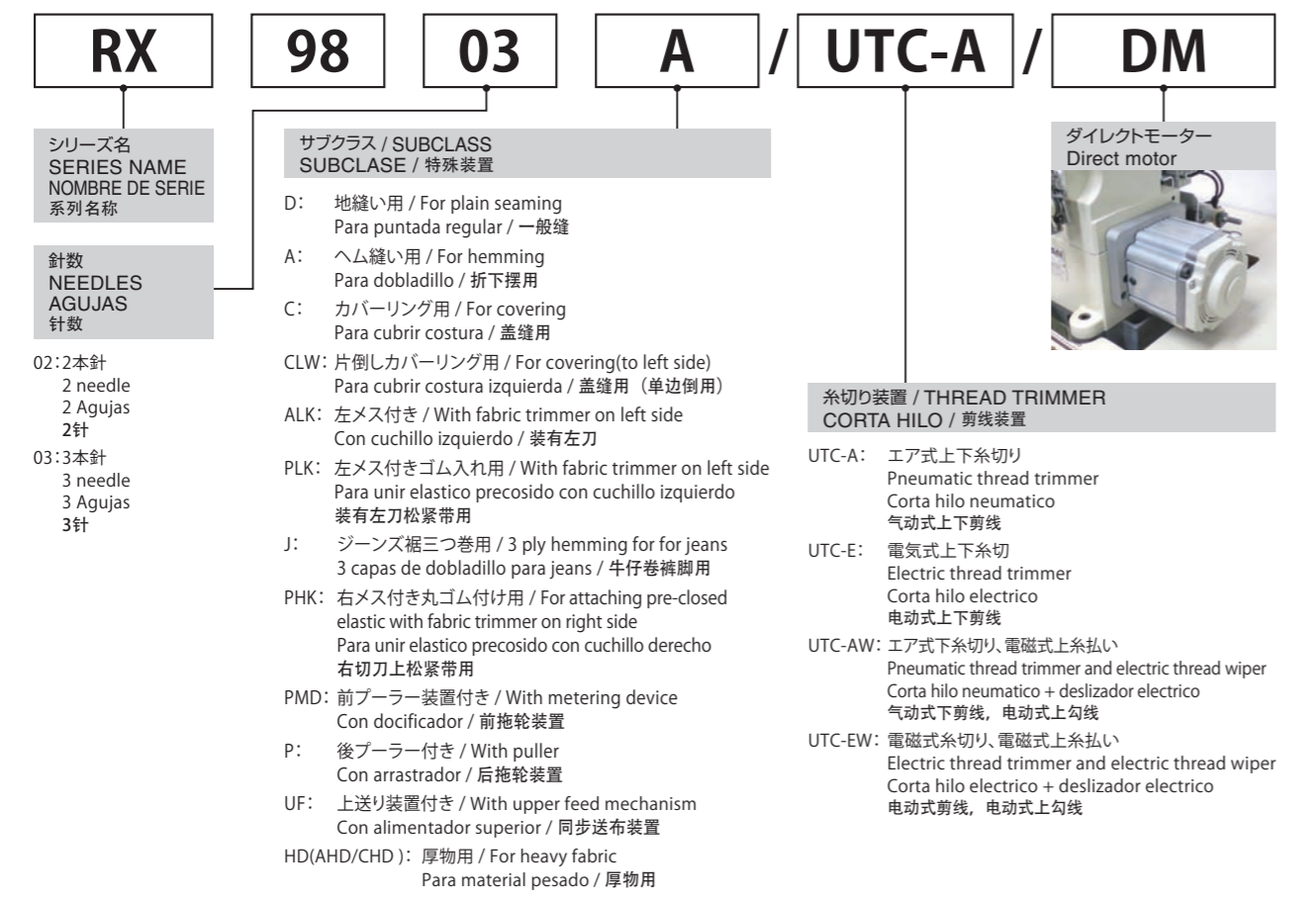

RX9803A RX9803D



RX9803A



RX9803A

3本針両面飾りセミシリンダー型裾引き用ミシン

3 needle, cylinder bed, top and bottom cover stitch machine for hemming.

3 agujas, cama cilíndrica, recubridor superior y inferior para dobladillos.

3 针两面装饰, 筒式绷缝机



MODEL	No. of Needle	No. of Thread	Needle Type		Gauge (Inch)	No. of Stitch (Stitch/Inch)	Diff. Feed Ratio	Presser Foot Lift (mm)	Needle Bar Stroke (mm)	Max. Speed (rpm)
			Organ (#)	Schmetz (Nm)						
RX9802A RX9802D(W)	2	4	UYX128GAS 9~14	UYX128GAS 60~90	1/8, 5/32, 3/16, 7/32, 1/4	6~16	0.3~2.9	6	33	6000
RX9803A RX9803D(W)	3	5	UYX128GAS 9~14	UYX128GAS 60~90	7/32, 1/4	6~16	0.3~2.9	6	33	6000
* RX9802A/UTC-A/E RX9802D(W)/UTC-AW/EW	2	4	UYX128GAS 9~14	UYX128GAS 60~90	1/8, 5/32, 3/16, 7/32, 1/4	6~16	0.3~2.9	6	33	6000
* RX9803A/UTC-A/E RX9803D(W)/UTC-AW/EW	3	5	UYX128GAS 9~14	UYX128GAS 60~90	3/16, 7/32, 1/4	6~16	0.3~2.9	6	33	6000

RX9803A-UF/UTC

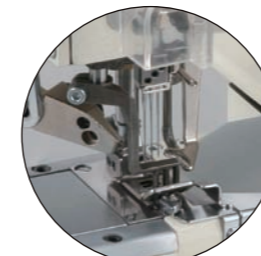
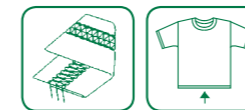

3本針上送り機構付きセミシリンダー型両面飾り裾引き用ミシン (自動糸切り装置付)

3 needle, cylinder bed, top and bottom cover stitch machine with upper feed mechanism for hemming.

Cama cilíndrica 3 agujas recubridor superior y inferior con alimentador superior para dobladillos.

3 针两面装饰, 筒式绷缝机

MODEL	No. of Needle	No. of Thread	Needle Type		Gauge (Inch)	No. of Stitch (Stitch/Inch)	Diff. Feed Ratio	Upper Feed Amount (mm)		Presser Foot Lift (mm)	Needle Bar Stroke (mm)	Max. Speed (rpm)
			Organ (#)	Schmetz (Nm)				↔	↑↓			
RX9802A-UF	2	4	UYX128GAS 9~14	UYX128GAS 60~90	3/16	8~16	0.3~2.9	1~7	3.5~6	6	33	5500
RX9803A-UF	3	5	UYX128GAS 9~14	UYX128GAS 60~90	7/32, 1/4	8~16	0.3~2.9	1~7	3.5~6	6	33	5500
* RX9802A-UF/UTC-A/E RX9802A-UF/UTC-AW/EW	2	4	UYX128GAS 9~14	UYX128GAS 60~90	3/16	8~16	0.3~2.9	1~7	3.5~6	6	33	5500
* RX9803A-UF/UTC-A/E RX9803A-UF/UTC-AW/EW	3	5	UYX128GAS 9~14	UYX128GAS 60~90	7/32, 1/4	8~16	0.3~2.9	1~7	3.5~6	6	33	5500

* UTC-A/E -- UTC is available as A (Air type-Pneumatic) or E (Electric type) for machine with top cover stitch

* UTC-AW/EW -- UTC is available as AW (Air type wiper) or EW (Electric type wiper) for machines without top cover stitch

RX9803CLW

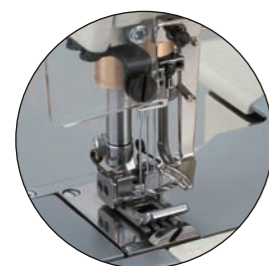

3本針両面飾りセミシリンダー型カバーリング用マシン

3 needle, cylinder bed, top and bottom cover stitch machine for left fold covering.

Cama cilíndrica 3 agujas recubridor superior e inferior.

Para pegar elastico, con arrastrador.

3 针两面装饰线迹包边缝边机

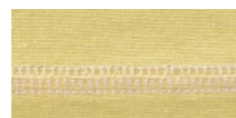

FRONT



BACK

MODEL	No. of Needle	No. of Thread	Needle Type		Gauge (Inch)	No. of Stitch (Stitch/Inch)	Diff. Feed Ratio	Presser Foot Lift (mm)	Needle Bar Stroke (mm)	Max. Speed (rpm)
			Organ (#)	Schmetz (Nm)						
RX9803C RX9803CC RX9803CLW	3	5	UYX128GAS 9~14	UYX128GAS 60~90	7/32, 1/4	6~16	0.3~2.9	6	33	6000
RX9803C/UTC-A/E RX9803CC/UTC-A/E RX9803CLW/UTC-A/E	3	5	UYX128GAS 9~14	UYX128GAS 60~90	7/32, 1/4	6~16	0.3~2.9	6	33	6000
RX9803C/UTC-AW/EW RX9803CC/UTC-AW/EW RX9803CLW/UTC-AW/EW	3	5	UYX128GAS 9~14	UYX128GAS 60~90	7/32	6~16	0.3~2.9	6	33	6000

COVERING MACHINES COMPARISON | comparación de las máquinas que cubre / 盖缝机的对比

TYPE	RX9803C	RX9803CC	RX9803CLW
	STANDARD GAUGE	STANDARD GAUGE	STANDARD GAUGE
C TYPE	STANDARD	IN ACCESSORY BOX	IN ACCESSORY BOX
CL TYPE		STANDARD	STANDARD
A TYPE		IN ACCESSORY BOX	

RX9803ALK



3本針両面飾りセミシリンダー裾引き用左メス付きマシン

3 needle, cylinder bed, top and bottom cover stitch machine with a fabric trimmer built in to the left of the needles for hemming

3 agujas, cama cilíndrica, recubridor superior e inferior con cuchillo izquierdo para dobladillo.

3 针两面装饰缝边带左切布刀

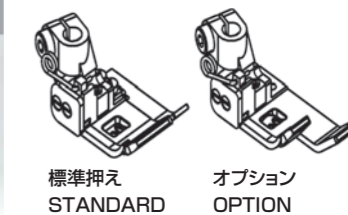

標準押え STANDARD

オプション OPTION

MODEL	No. of Needle	No. of Thread	Needle Type		Gauge (Inch)	No. of Stitch (Stitch/Inch)	Diff. Feed Ratio	Presser Foot Lift (mm)	Needle Bar Stroke (mm)	Max. Speed (rpm)
			Organ (#)	Schmetz (Nm)						
RX9802ALK	2	4	UYX128GAS 9~14	UYX128GAS 60~90	5/32, 3/16	6~16	0.3~2.9	6	33	5500
RX9803ALK	3	5	UYX128GAS 9~14	UYX128GAS 60~90	3/16, 7/32, 1/4	6~16	0.3~2.9	6	33	5500
RX9802ALK/UTC	2	4	UYX128GAS 9~14	UYX128GAS 60~90	5/32, 3/16	6~16	0.3~2.9	6	33	5500
RX9803ALK/UTC	3	5	UYX128GAS 9~14	UYX128GAS 60~90	3/16, 7/32, 1/4	6~16	0.3~2.9	6	33	5500

RX9803P

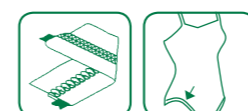

P - Gear puller
PE - Smooth puller



3本針両面飾りセミシリンダー、プーラー、ゴム入れ用マシン

3 needle, cylinder bed, top and bottom cover stitch machine with rear puller for attaching elastic.

Cama cilíndrica 3 agujas recubridor superior e inferior. Para pegar elastico, con arrastrador.

3 针两面装饰线迹缝边带后拖轮，可以上松紧带

MODEL	No. of Needle	No. of Thread	Needle Type		Gauge (Inch)	No. of Stitch (Stitch/Inch)	Diff. Feed Ratio	Presser Foot Lift (mm)	Needle Bar Stroke (mm)	Max. Speed (rpm)
			Organ (#)	Schmetz (Nm)						
RX9803P	3	5	UYX128GAS 9~14	UYX128GAS 60~90	7/32, 1/4	6~16	0.3~2.9	6	33	4800
※ RX9803P/UTC-A/E RX9803P/UTC-AW/EW	3	5	UYX128GAS 9~14	UYX128GAS 60~90	7/32, 1/4	6~16	0.3~2.9	6	33	4800

※ UTC-A/E -- UTC is available as A (Air type-Pneumatic) or E (Electric type) for machine with top cover stitch

※ UTC-AW/EW -- UTC is available as AW (Air type wiper) or EW (Electric type wiper) for machines without top cover stitch

RX9803PEHK



3本針下面飾りセミシリンダー
天ゴム付け用マシン

3 needle, cylinder bed machine
with fabric trimmer and smooth
puller for attaching pre-closed
elastic to men's underwears..

3 agujas, máquina de cama de
cilindro con la recortadora de
tejido y el puller liso por atar el
preclosed elástico a las ropas
interior de hombres

3 针圆筒上松紧带缝纫机



• PEHK:Smooth Puller
• PGHK:Gear puller



■ RX-PHKのメスドロップ機構 / Drop knife system El sistema de caída de cuchillo / RX-PHK的刀组闲置装置

矢印のボタンとレバーにより、針板下面
で上メスの駆動を止めることができます。
メスを必要としない縫製の場合に、御使
用ください。

By pushing Button A & Lever B,
the height of the knife can be set
up under the surface of the needle
plate.
It is useful for the sewing operation
without fabric trimmer.

Empujando Botón UN & Palanca
B, la altura del cuchillo puede
prepararse bajo la superficie del
plato de la aguja.

Es útil para el funcionamiento de la
costura sin la recortadora de tejido.

使用箭头所指的按钮和连杆可以控制针板下面刀组的运动。
在缝制操作上不需要用刀的时候，可以采用这项功能。

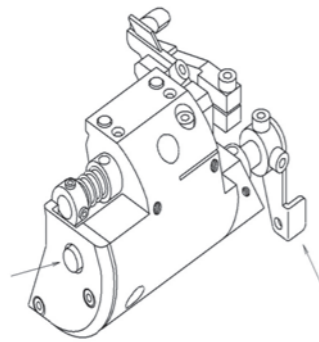

■ プーラーは仕様によりギヤーまたはゴムプーラーが選べいただけます。 Please choose either "Gear puller (PG-HK)" or "Smooth puller (PE-HK)" depending on your specification Se puede elegir "Puller de diente (PG-HK)" o "Puller de goma (PE-HK)" dependiendo de su especificación 根据缝制的要求可选择使用齿轮拖轮和橡胶平拖轮。

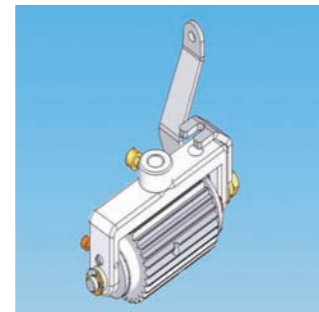

PG-HK
(Gear puller)

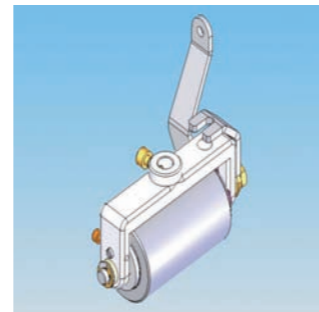

PE-HK
(Smooth puller)

MODEL	No. of Needle	No. of Thread	Needle Type		Gauge (Inch)	No. of Stitch (Stitch/Inch)	Diff. Feed Ratio	Presser Foot Lift (mm)	NeedleBar Stroke (mm)	Max. Speed (rpm)
			Organ (#)	Schmetz (Nm)						
RX9803PEHK (with smooth puller)	3	5	UYX128GAS 9~14	UYX128GAS 60~90	7/32, 1/4	8~16	0.3~2.9	5	33	4800
RX9803PGHK (with gear puller)	3	5	UYX128GAS 9~14	UYX128GAS 60~90	7/32, 1/4	8~16	0.3~2.9	5	33	4800
RX9803PEHK/UTC (with smooth puller)	3	5	UYX128GAS 9~14	UYX128GAS 60~90	7/32, 1/4	8~16	0.3~2.9	5	33	4800
RX9803PGHK/UTC (with gear puller)	3	5	UYX128GAS 9~14	UYX128GAS 60~90	7/32, 1/4	8~16	0.3~2.9	5	33	4800

RX9803PLK

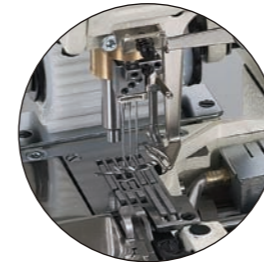
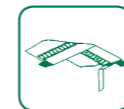

3本針両面飾りセミシリンダープーラー付、
左メス付、ゴム入れ用マシン

3 needle, cylinder bed, top and
bottom cover stitch machine with
fabric trimmer and rear puller for
inserting elastic.

Cama cilíndrica 3 agujas
recubridor superior e inferior; con
arrastrador y cuchillo de izquierdo
para cortar bordes.

3 针筒式绷缝机。
(带后拖轮、左切刀、上松紧带用装置)

MODEL	No. of Needle	No. of Thread	Needle Type		Gauge (Inch)	No. of Stitch (Stitch/Inch)	Diff. Feed Ratio	Presser Foot Lift (mm)	NeedleBar Stroke (mm)	Max. Speed (rpm)
			Organ (#)	Schmetz (Nm)						
RX9802PLK	2	4	UYX128GAS 9~14	UYX128GAS 60~90	5/32, 3/16	6~16	0.3~2.9	6	33	4800
RX9803PLK	3	5	UYX128GAS 9~14	UYX128GAS 60~90	7/32, 1/4	6~16	0.3~2.9	6	33	4800
RX9802PLK/UTC	2	4	UYX128GAS 9~14	UYX128GAS 60~90	5/32, 3/16	6~16	0.3~2.9	5	33	4800
RX9803PLK/UTC	3	5	UYX128GAS 9~14	UYX128GAS 60~90	7/32, 1/4	6~16	0.3~2.9	5	33	4800

RX9701J



1本針二重環縫いセミシリンダー裾
ミツ巻用マシン

1 needle, cylinder bed, double
chain stitch machine with three ply
hemming folder.

1 aguja, cama del cilindro, máquina
de puntada de cadena doble con
tres cabo que dobladilla la carpeta,

单针牛仔卷边、筒式、双重环缝纫机

MODEL	No. of Needle	No. of Thread	Needle Type		Gauge (Inch)	No. of Stitch (Stitch/Inch)	Diff. Feed Ratio	Presser Foot Lift (mm)	NeedleBar Stroke (mm)	Max. Speed (rpm)
			Organ (#)	Schmetz (Nm)						
RX9701J	1	2	TVX5 21			6~11		8	34	4000
RX9701J-CD/UTC	1	2	TVX5 21			6~11		8	34	4000

1 aguja, cama del cilindro, máquina
de puntada de cadena doble con
tres cabo que dobladilla la carpeta,

单针牛仔卷边、筒式、双重环缝纫机

1本針二重環縫いセミシリンダー裾
ミツ巻用マシン

1 needle, cylinder bed, double
chain stitch machine with three ply
hemming folder.

1 aguja, cama del cilindro, máquina
de puntada de cadena doble con
tres cabo que dobladilla la carpeta,

单针牛仔卷边、筒式、双重环缝纫机

REX9803MG



3本針両面飾り縫い外部ハマグリ機構
マシン マルチゲージ(A,D,C,CL,F)

3 needle, cylinder bed, top and bottom cover stitch machine with exterior looper thread takeup cam(5 type gauge sets included).

3 agujas, cama del cilindro, cima y máquina de puntada de tapa de fondo con looper exterior enhebran la toma a la leva (5 juegos de medida de tipo incluyeron)

3 针两面缝装饰缝机 (筒式台, 打线器设定在外边, 可以选各种针位)



Tape binding / Pegar cinta / 滚条

MODEL	No. of Needle	No. of Thread	Needle Type		Gauge (Inch)	No. of Stitch (Stitch/Inch)	Diff. Feed Ratio	Presser Foot Lift (mm)	Needle Bar Stroke (mm)	Max. Speed (rpm)
			Organ (#)	Schmetz (Nm)						
REX9802MG	2	4	UYX128GAS 9~14	UYX128GAS 60~90	3/16	6~16	0.3~2.9	6	33	6000
REX9803MG	3	5	UYX128GAS 9~14	UYX128GAS 60~90	7/32, 1/4	6~16	0.3~2.9	6	33	6000
※ REX9802MG/UTC-A/E REX9802MG/UTC-AW/EW	2	4	UYX128GAS 9~14	UYX128GAS 60~90	3/16	6~16	0.3~2.9	6	33	6000
※ REX9803MG/UTC-A/E REX9803MG/UTC-AW/EW	3	5	UYX128GAS 9~14	UYX128GAS 60~90	7/32, 1/4	6~16	0.3~2.9	6	33	6000

※ UTC-A/E -- UTC is available as A (Air type-Pneumatic) or E (Electric type) for machine with top cover stitch

D type Plain / Puntada regular / 辅助平台 Plain

C/CL type Covering / Cubrir costuras de overlock / 盖缝 Plain to Covering

F type Tape binding / Pegar cinta / 滚条 Plain to Tape binding

A type Hemming / Doblado / 折下摆 Plain to Hemming

REX9803D



3本針両面飾り縫いセミシリンダー外部
ハマグリ機構マシン

3 needle, cylinder bed, top and
bottom cover stitch machine with
exterior looper thread takeup cam.

3 agujas, cama del cilindro, cima
y máquina de puntada de tapa de
fondo con looper exterior enhebran
la toma a la leva

3 针两面缝装饰绷缝机
(筒式台, 打线器设定在外边)



MODEL	No. of Needle	No. of Thread	Needle Type		Gauge (Inch)	No. of Stitch (Stitch/Inch)	Diff. Feed Ratio	Presser Foot Lift (mm)	NeedleBar Stroke (mm)	Max. Speed (rpm)
			Organ (#)	Schmetz (Nm)						
REX9802D	2	4	UYX128GAS 9~14	UYX128GAS 60~90	3/16	6~16	0.3~2.9	6	33	6000
REX9803D	3	5	UYX128GAS 9~14	UYX128GAS 60~90	7/32, 1/4	6~16	0.3~2.9	6	33	6000
※ REX9802D/UTC-A/E REX9802D/UTC-AW/EW	2	4	UYX128GAS 9~14	UYX128GAS 60~90	3/16	6~16	0.3~2.9	6	33	6000
※ REX9803D/UTC-A/ EREX9803D/UTC-AW/EW	3	5	UYX128GAS 9~14	UYX128GAS 60~90	7/32, 1/4	6~16	0.3~2.9	6	33	6000

REX9803CL



3本針両面飾り縫いセミシリンダー、外部
ハマグリ機構カバーリング用マシン
マルチゲージ(A,D,C,CL)

3 needle, cylinder bed, top and
bottom cover stitch machine with
exterior looper thread takeup
cam(4 type gauge set included).

3 agujas, cama del cilindro, cima
y máquina de puntada de tapa de
fondo con looper exterior enhebran
la toma a la leva(4 juegos de
medida de tipo incluyeron)

3 针两面缝装饰, 单面到盖缝绷缝机
(筒式台, 打线器设定在外边, 可以选各
种针位)



REX9803C

REX9803CL

MODEL	No. of Needle	No. of Thread	Needle Type		Gauge (Inch)	No. of Stitch (Stitch/Inch)	Diff. Feed Ratio	Presser Foot Lift (mm)	NeedleBar Stroke (mm)	Max. Speed (rpm)
			Organ (#)	Schmetz (Nm)						
REX9802CL	2	4	UYX128GAS 9~14	UYX128GAS 60~90	3/16	6~16	0.3~2.9	6	33	6000
REX9803CL	3	5	UYX128GAS 9~14	UYX128GAS 60~90	7/32, 1/4	6~16	0.3~2.9	6	33	6000
※ REX9802CL/UTC-A/E REX9802CL/UTC-AW/EW	2	4	UYX128GAS 9~14	UYX128GAS 60~90	3/16	6~16	0.3~2.9	6	33	6000
※ REX9803CL/UTC-A/E REX9803CL/UTC-AW/EW	3	5	UYX128GAS 9~14	UYX128GAS 60~90	7/32, 1/4	6~16	0.3~2.9	6	33	6000

※ UTC-A/E -- UTC is available as A (Air type-Pneumatic) or E (Electric type) for machine with top cover stitch

※ UTC-AW/EW -- UTC is available as AW (Air type wiper) or EW(Electric type wiper) for machines without top cover stitch

IRX OTHER SERIES | TECHNICAL DATA 仕様詳細

MODEL	No. of Needle	No. of Thread	Needle Type		Gauge(Inch)	No. of Stitch (Stitch/Inch)	Diff. Feed Ratio	Upper Feed Amount (mm)		Presser Foot Lift (mm)	NeedleBar Stroke (mm)	Max. Speed (rpm)
			Organ (#)	Schmetz (Nm)				↔	↕			
REX9802C	2	4	UYX128GAS 9~14	UYX128GAS 60~90	3/16, 7/32, 1/4	6~16	0.3~2.9			6	33	6000
※ REX9802C/UTC-A/E	2	4	UYX128GAS 9~14	UYX128GAS 60~90	3/16, 7/32, 1/4	6~16	0.3~2.9			6	33	6000
REX9803-CHD	3	5	UYX128GAS 9~14	UYX128GAS 60~90	7/32, 1/4	6~16	0.3~2.9			6	33	6000
※ REX9803-CHD/ UTC-A/E	3	5	UYX128GAS 9~14	UYX128GAS 60~90	7/32, 1/4	6~16	0.3~2.9			6	33	6000
REX9802P	2	4	UYX128GAS 9~14	UYX128GAS 60~90	5/32, 3/16	6~16	0.3~2.9			6	33	4800
REX9802P/UTC-A/E	2	4	UYX128GAS 9~14	UYX128GAS 60~90	5/32, 3/16	6~16	0.3~2.9			6	33	4800
REX9803-AHD	3	5	UYX128GAS 9~14	UYX128GAS 60~90	7/32, 1/4	6~16	0.3~2.9			6	33	6000
※ REX9803-AHD/ UTC-A/E	3	5	UYX128GAS 9~14	UYX128GAS 60~90	7/32, 1/4	6~16	0.3~2.9			6	33	6000
REX9803C-UF	3	5	UYX128GAS 9~14	UYX128GAS 60~90	7/32, 1/4	8~16	0.3~2.9	1~7	3.5~6	6	33	5500
※ REX9803C-UF/ UTC-A/E	3	5	UYX128GAS 9~14	UYX128GAS 60~90	7/32, 1/4	8~16	0.3~2.9	1~7	3.5~6	6	33	5500
※ REX9802C-UF	2	4	UYX128GAS 9~14	UYX128GAS 60~90	3/16	8~16	0.3~2.9	1~7	3.5~6	6	33	5500
※ REX9802C-UF/ UTC-A/E	2	4	UYX128GAS 9~14	UYX128GAS 60~90	3/16	8~16	0.3~2.9	1~7	3.5~6	6	33	5500

※ UTC-A/E -- UTC is available as A (Air type-Pneumatic) or E (Electric type) for machine with top cover stitch

※ UTC-AW/EW -- UTC is available as AW (Air type wiper) or EW(Electric type wiper) for machines without top cover stitch

DM (Direct motor) is available for machines with UTC device only. (UTC-A/E-DM, UTC-AW/EW-DM)

NM SERIES

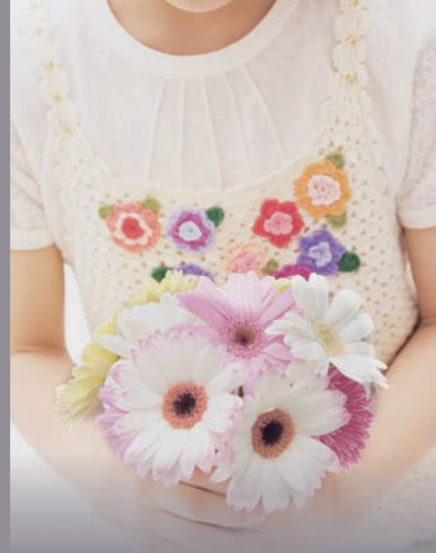

NMシリーズは、超極細シリンダーヘッド(外径180mm)、高速・高性能両面飾り偏平縫いミシンです。子供服、ベビー服などの袖口のカバーリング、ヘム縫い、首周り、婦人用ストッキング、ショーツなどの縫製に最適です。差動送り装置付きですので、伸縮性のある素材もきれいに仕上がります。

NM series is an ultra small cylinder bed (circumference 180mm), top and bottom cover stitch machine for high speed and reliable performance. Applications: overlock cover seaming and hemming. Major features of this series are ultra small cylinder bed, differential feed mechanism and micro adjust stitch regulator. NM series is well suited for sewing sleeve cuffs, neck opening of infants' clothing, children's clothing, as well as ladies' stockings.

NM serie de alta velocidad con recubridor, superior e inferior, cilindro pequeño (circunferencia 180mm). Esta maquina es la ideal para coser mangas, punos, cuello, en ropa de niño (ribete y recubridor) medias para senora, etc. Esta serie produce terminados muy buenos, incluyendo en telas estrechables, porque esta equipada con mecanismo de alimentador diferencial.

NM 系列为超级细筒式(外周 180mm) 高速、高性能两面绷缝机。儿童服装的袖口，包边，领口，妇女的裤袜等最为合适，带差动送布，也可以缝伸缩性的布料。

NMモデル表示方法

NM	11	03	A	UTC-A
シリーズ名 SERIES NAME NOMBRE DE SERIE 系列名称	針数 / NEEDLES AGUJAS / 针数	サブクラス / SUBCLASS SUBCLASE / 特殊装置	糸切り装置 / THREAD TRIMMER CORTA HILO / 剪线装置	
	02: 2本針 2 needle 2 Agujas 2针 03: 3本針 3 needle 3 Agujas 3针	A: ヘム縫い用 For hemming Para dobladillo 折下摆 C: カバーリング用 For covering Para cubrir costura 盖缝用 CL: カバーリング(片倒し) For covering (to left side) Para cubrir costura izquierda 盖缝用(单边倒用) UF: 上送り装置 Upper feed Con alimentador superior 同步送布装置	UTC-A: エア式上下糸切り Pneumatic thread trimmer Corta hilo neumatico 气动式上下切线 UTC-E: 電気式上下糸切 Electric thread trimmer Corta hilo electrico 电动式上下切线 UTC-AW: エア式下糸切り、電磁式上糸払い Pneumatic thread trimmer and electric thread wiper Corta hilo neumatico + deslizador electrico 气动式下剪线，电动式上勾线 UTC-EW: 電磁式糸切り、電磁式上糸払い Electric thread trimmer and Electric thread wiper Corta hilo electrico + deslizador electrico 电动式剪线，电动式上勾线	

NM1103A

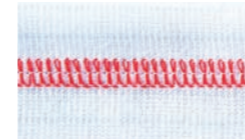
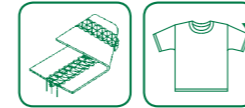

3本針極細シリンダーヘッド偏平縫いヘム縫い用ミシン

3 needle, ultra small cylinder bed, top and bottom cover stitch machine for hemming.

3 agujas, cama cilíndrica pequeña, recubridor superior e inferior para dobladillo.

3 针两面装饰卷边用绷缝机

MODEL	No. of Needle	No. of Thread	Needle Type		Gauge (Inch)	No. of Stitch (Stitch/Inch)	Diff. Feed Ratio	Presser Foot Lift (mm)	Needle Bar Stroke (mm)	Max. Speed (rpm)
			Organ (#)	Schmetz (Nm)						
NM1102A	2	4	UYX128GAS 9~14	UYX128GAS 60~90	1/8, 5/32, 3/16	7~16	0.8~1.4	6	33	4500
NM1103A	3	5	UYX128GAS 9~14	UYX128GAS 60~90	3/16, 7/32, 1/4	7~16	0.8~1.4	6	33	4500
NM1102A/UTC-A/E NM1102A/UTC-AW/EW	2	4	UYX128GAS 9~14	UYX128GAS 60~90	1/8, 5/32, 3/16	7~16	0.8~1.4	6	33	4500
NM1103A/UTC-A/E NM1103A/UTC-AW/EW	3	5	UYX128GAS 9~14	UYX128GAS 60~90	3/16, 7/32, 1/4	7~16	0.8~1.4	6	33	4500

NM1103A-UF-UTC-A

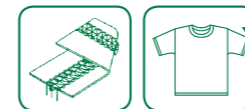

3本針両面飾り極細シリンダー上下送り付裾引き用ミシン(自動糸切り装置付)

3 needle, ultra small cylinder bed top and bottom cover stitch machine with upper feed mechanism and pneumatic thread trimmer for hemming.

Maquinas de cilindro pequeño con alimentador superior y recubridor superior e inferior, cortador de hilos automaticos, para dobladillo.

3 针两面装饰卷边用绷缝机带上下送布牙

MODEL	No. of Needle	No. of Thread	Needle Type		Gauge (Inch)	No. of Stitch (Stitch/Inch)	Diff. Feed Ratio	Upper Feed Amount (mm)		Presser Foot Lift (mm)	Needle Bar Stroke (mm)	Max. Speed (rpm)
			Organ (#)	Schmetz (Nm)				←	↑			
NM1102A-UF	2	4	UYX128GAS 9~14	UYX128GAS 60~90	3/16	7~16	0.8~1.4	1~7	3.5~6	6	33	4500
NM1103A-UF	3	5	UYX128GAS 9~14	UYX128GAS 60~90	7/32, 1/4	7~16	0.8~1.4	1~7	3.5~6	6	33	4500
NM1102A-UF/UTC-A/E NM1102A-UF/UTC-AW/EW	2	4	UYX128GAS 9~14	UYX128GAS 60~90	3/16	7~16	0.8~1.4	1~7	3.5~6	6	33	4500
NM1103A-UF/UTC-A/E NM1103A-UF/UTC-AW/EW	3	5	UYX128GAS 9~14	UYX128GAS 60~90	7/32, 1/4	7~16	0.8~1.4	1~7	3.5~6	6	33	4500

NM1103CL-UTC-A

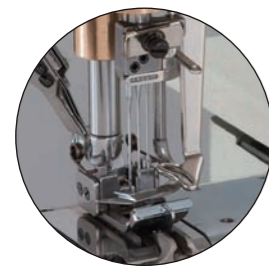

3本針両面飾り片倒しカバーリング用ミシン
(自動糸切り装置付)

3 needle, ultra small cylinder bed,
top and bottom cover stitch machine
with pneumatic thread trimmer for
covering left fold of overlock seams.

Cama cilíndrica, 3 agujas,
recubridor superior e inferior, con
cortador de hilos automáticos para
coser la costura previa de overlock,
para la mejor calidad de la prenda.

3 针两面装饰单面倒盖缝及中间缝两用绷
缝机

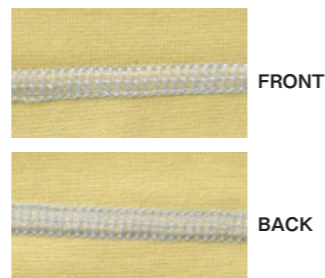

MODEL	No. of Needle	No. of Thread	Needle Type		Gauge (Inch)	No. of Stitch (Stitch/Inch)	Diff. Feed Ratio	Presser Foot Lift (mm)	Needle Bar Stroke (mm)	Max. Speed (rpm)
			Organ (#)	Schmetz (Nm)						
NM1103CL	3	5	UYX128GAS 9~14	UYX128GAS 60~90	7/32, 1/4	7~16	0.8~1.4	6	33	4500
NM1103CL/UTC-A/E NM1103CL/UTC-AW/EW	3	5	UYX128GAS 9~14	UYX128GAS 60~90	7/32, 1/4	7~16	0.8~1.4	6	33	4500

NM SERIES | TECHNICAL DATA 仕様明細

MODEL	No. of Needle	No. of Thread	Needle Type		Gauge (Inch)	No. of Stitch (Stitch/Inch)	Diff. Feed Ratio	Upper Feed Amount (mm)		Presser Foot Lift (mm)	Needle Bar Stroke (mm)	Max. Speed (rpm)
			Organ (#)	Schmetz (Nm)				↔	↕			
NM1102C	2	4	UYX128GAS 9~14	UYX128GAS 60~90	5/32, 3/16	7~16	0.8~1.4			6	33	4500
※ NM1102C-TC-A/E	2	4	UYX128GAS 9~14	UYX128GAS 60~90	5/32, 3/16	7~16	0.8~1.4			6	33	4500
NM1103C	3	5	UYX128GAS 9~14	UYX128GAS 60~90	7/32, 1/4	7~16	0.8~1.4			6	33	4500
※ NM1103C-UTC-A/E	3	5	UYX128GAS 9~14	UYX128GAS 60~90	7/32, 1/4	7~16	0.8~1.4			6	33	4500
※ NM1103C-UTC-AW/EW	3	4	UYX128GAS 9~14	UYX128GAS 60~90	7/32, 1/4	7~16	0.8~1.4			8	33	4500
NM1102C-UF	2	4	UYX128GAS 9~14	UYX128GAS 60~90	3/16	7~16	0.8~1.4	1~7	3.5~6	6	33	4500
※ NM1102C-UF-UTC-A/E	2	4	UYX128GAS 9~14	UYX128GAS 60~90	3/16	7~16	0.8~1.4	1~7	3.5~6	6	33	4500
NM1103C-UF	3	5	UYX128GAS 9~14	UYX128GAS 60~90	7/32, 1/4	7~16	0.8~1.4	1~7	3.5~6	6	33	4500
※ NM1103C-UF-UTC-A/E	3	5	UYX128GAS 9~14	UYX128GAS 60~90	7/32, 1/4	7~16	0.8~1.4	1~7	3.5~6	6	33	4500

※ UTC-A/E -- UTC is available as A (Air type-Pneumatic) or E (Electric type) for machine with top cover stitch

※ UTC-AW/EW -- UTC is available as AW (Air type wiper) or EW (Electric type wiper) for machines without top cover stitch

COVERING MACHINES COMPARISON | comparación de las máquinas que cubre / 盖缝机的相比

TYPE	NM1103C		NM1103CL	
	STANDARD GAUGE		STANDARD GAUGE	
C TYPE	STANDARD		IN ACCESSORY BOX	
CL TYPE	/		STANDARD	

FSX SERIES

FSXシリーズは、フラットシーム用4本針6糸系両面飾り腕送り出し扁平縫いミシンです。高級下着やスポーツウェアなどの継ぎ合わせ、プリーズの股下合わせ等に適しています。片切りまたは両切りの生地カットによるごろつきのないフラットな仕上がりがや股合わせ縫いの段部での縫製など、薄物～厚物まで様々な用途に対応するためにバリエーションも豊富に揃えております。腕送り出し型ですので、筒物や丸物の作業に適しています。

FSX series, 4 needle, 6 thread, feed-off-the-arm, top and bottom cover stitch machine. This machine is suitable for overlapping such as joining of high quality under wear, sport wear and inseaming of brief. Equipped with one side cut or both side cut trimmer, this system guarantees flat shape neat finish completely, in order materialize versatile applications from thin to heavy materials such as inseaming of brief's cross seams. Design of this feed-off-the-arm is perfect for tubular garments.

La serie FSX de 4 agujas y 6 hilos, alimentacion de brazo, recubridor superior y inferior. Esta maquina es apropiada para sobrecoser y juntar ropa interior y deportiva. Equipada con corte par uno y dos lados, este sistema garantiza un terminado completamente nitido. Para aplicaciones versatiles, de materiales livianos o pesados, apropiado para coser donde hay sbrecosturas, alimentacion de brazo, es perfecto para prendas tubulares.

FSX 系列，拼缝用两面装饰线迹 4 针 6 线双切式伸出手臂式绷缝机高级内衣裤，运动装等缝制边时拼合左右的布料边缝制，也适合公事包的下挡拼合缝等通过单片切和两片切，缝制边时拼合左右的布料边缝制，缝制重叠部分是一定的，缝成后非常美观。从薄布料到中厚布料的各种各样的加工种类因为是伸出手臂型，所以适合筒物和圈物的加工

FBXシリーズ 表示方法

FSX	66	04	LM	-	CS-2
シリーズ名 SERIES NAME NOMBRE DE SERIE 系列名称		針数 NEEDLES AGUJAS 针数	用途 OBJECT APLICACION 他機種参照		オプション OPTIONS OPCIÓN 选项
		04:4本針 4 needle 4 agujas 4針	S: 片切り Trimming left side edge. Borde del lado izquierdo arreglando 单切刀 LM: 薄物～中厚物 For light to medium heavy fabric. Para la luz al tejido pesado elemento 薄布料到中厚布料用 MH: 中厚物～厚物 For medium to heavy fabric. Para el tejido pesado elemento al tejido pesado 中厚布料到厚布料用 MH-B: 厚物突合せ For butt seaming. Por extremo coser 厚料接縫		CS-2: 電気式空環切り装置 Electric chain cutter Cortador de cadeneta 气动式切空线环装置 DD: ダイレクトモーター Direct motor Motor directo 直驱马达 FL: エア式押え上げ装置 Pneumatic foot lifter Levanta pie pneumatico 气动式抬压脚装置

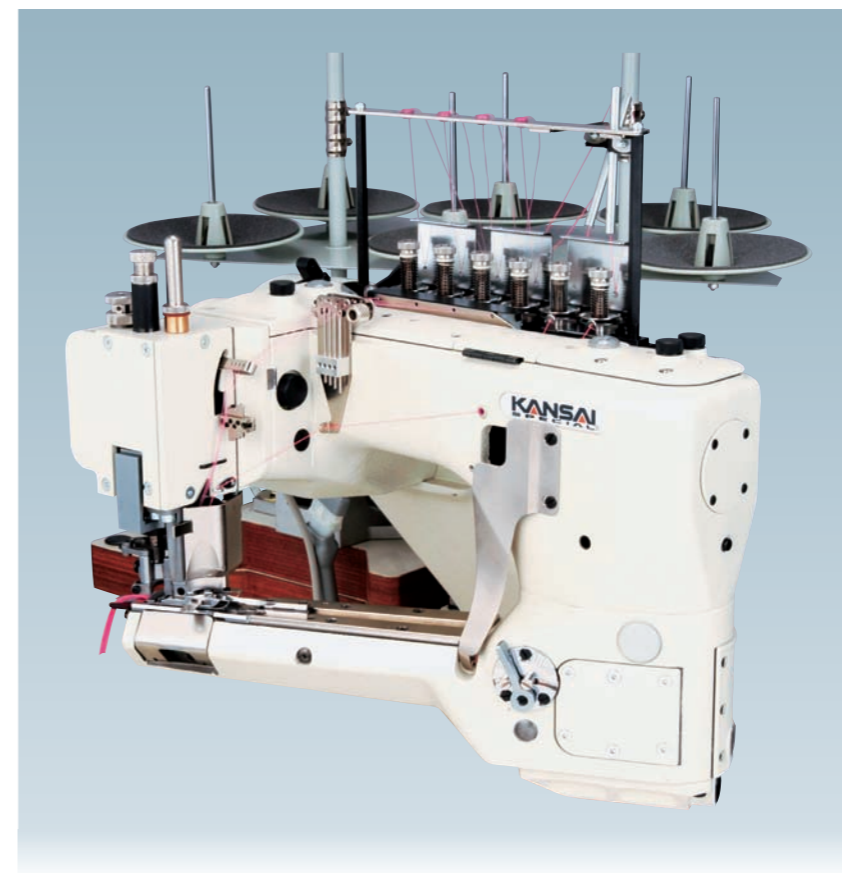

FSX6604S

4本針上飾り付片切り式フラットシーマ
(薄～中厚用) プリーズの股継ぎ、Tシャツの袖閉じ縫い用、
一般的には生地左側をカットします。

4 needle, with top cover stitch, single edge cut type
flat seamer.
For joining the crotch of brief and T-shirts sleeves.

4 agujas recubridor superior, corte sencillo de
borde en costura, plana, union de costura, entre-
pierna, y mangas de camiseta.

4 针 6 线装饰线迹伸臂单切式拼缝机(薄布料到中厚布料用)
适用于内衣、内裤、短袖、上衣等

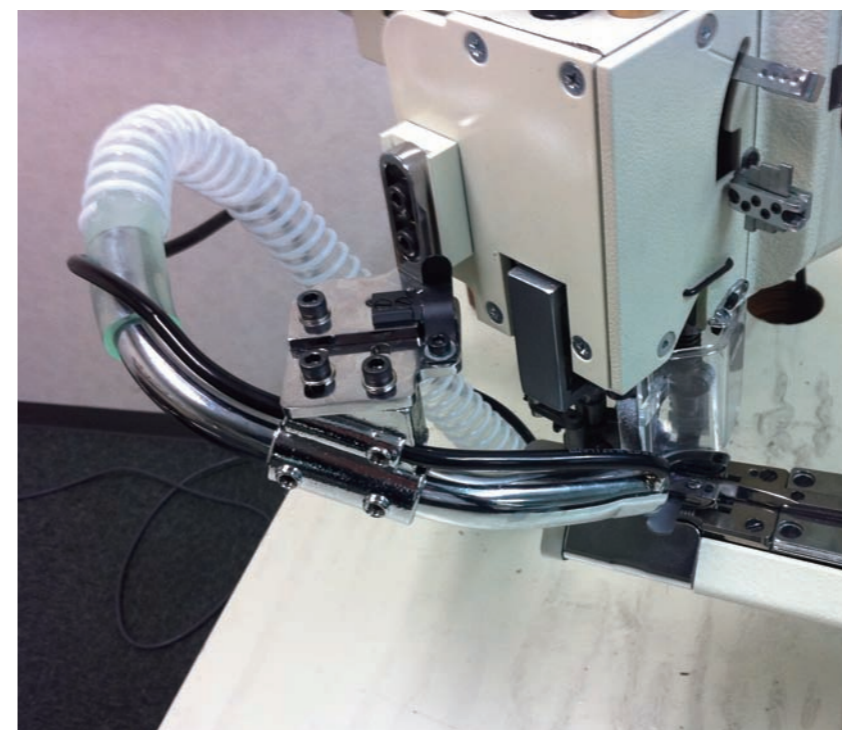
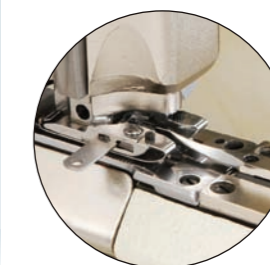

FSX6604LM

4本針上飾り付き両切り式フラットシーマ(薄～中厚用)。
Tシャツの肩継ぎ、身頃の継ぎ合わせ用。両切り押えにより左
右の生地をカットしながら縫いずれなくきれいに縫い合わせ
することができます。

4 needle with top cover stitch, both side edge cut
type flat seamer. Suitable for joining the cloth of brief
and T-shirt sleeves.
Both side edge trimmer can solve the puckering of
material cutting and get a beautiful stitch formation.

4 agujas, recubridor superior, corte de borde en
los dos lados. Union de costura, entre-pierna, y
mangas de camiseta, al tener corte en los dos
lados, no permite que el material forme arrugas,
para una formacion de puntada muy bonita.

4 针 6 线装饰线迹田臂单切式拼缝机带双片切
(薄布料到中厚布料用)

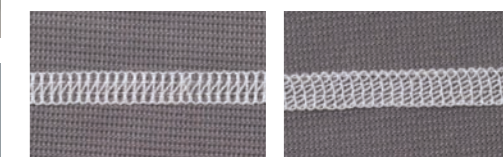

FRONT

BACK

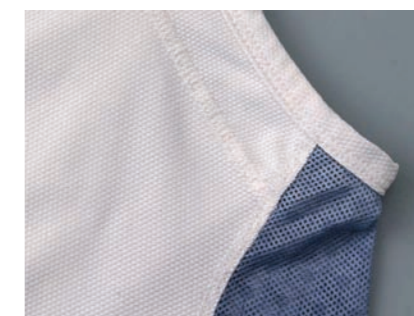

FSX6604MH-DD

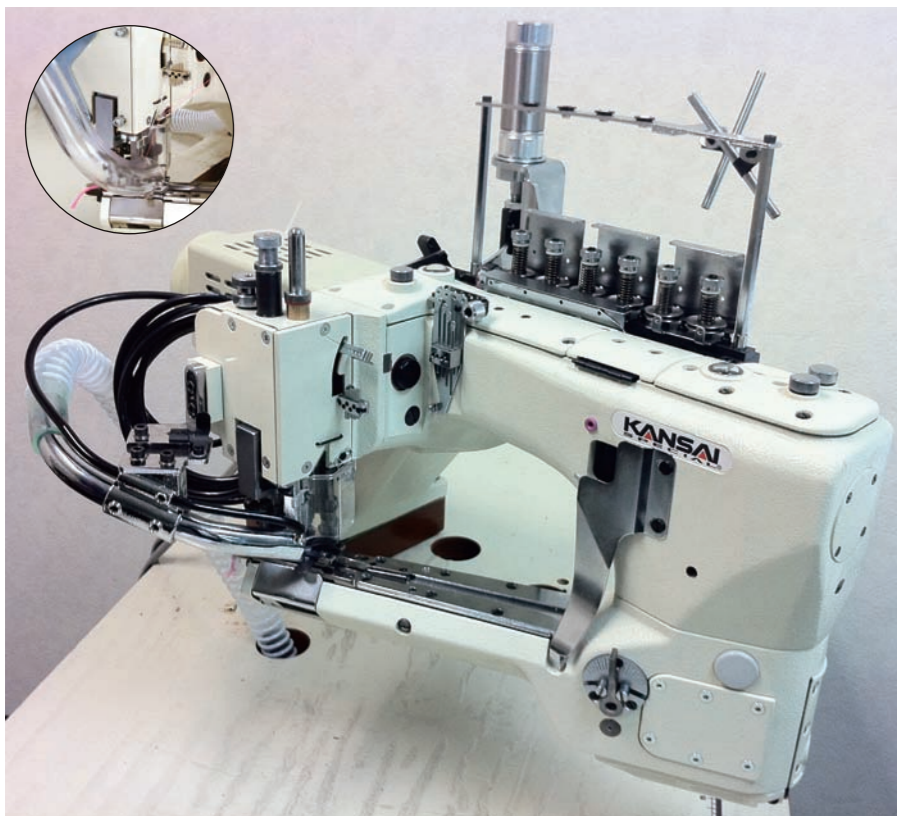

4本針上飾り付両切式フラットシーマ(中厚~厚物用)
ブリーフの股合わせの段部や厚物の合わせ縫いにも
縫いスレ縫いはすれなくきれいに縫い合わせることが
できます。

4 needle, with top cover stitch, both side
edge cut type flat seamer Suitable for the
closing the crotch of brief with thick parts
like a tape binding and heavy material,

4 agujas, recubridor superior corte de borde
en ambos lados, costura plana, para cerrar
costura de entre- - piernas, con cinta en
materiales pesados

4 针 6 线装饰线迹田臂单切式拼缝机
(中厚布料到厚布料)

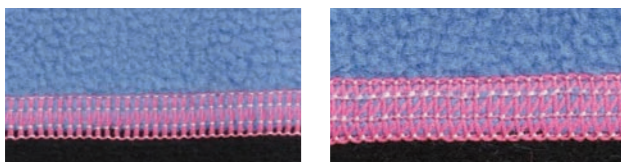

テーブルはゆったりした作業
スペースを確保しデジタル
ハンドプーリー(安全装置付)
を採用しました。

標準装備 | STANDARD EQUIPMENT / Equipo normal / 标准配件

DD ダイレクトモーター DIRECT MOTOR

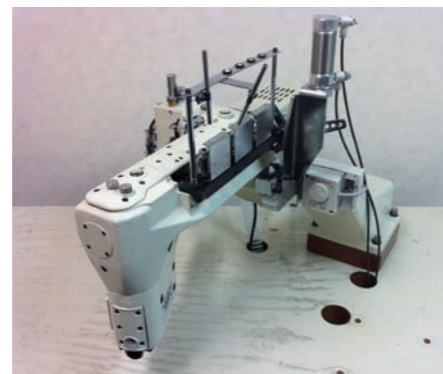
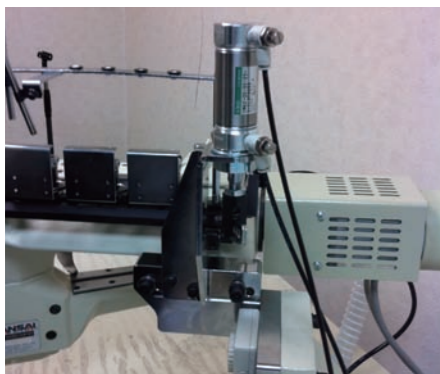

デジタルプーリー (ダイレクトモーター取付時)
digital pulley
(in case of direct motor attached "Direct motor")

■ 押さえの比較 / Comparison between the pressure foot LM type and MH type / Comparacion entre pie de presion LM y MH / 押脚比较

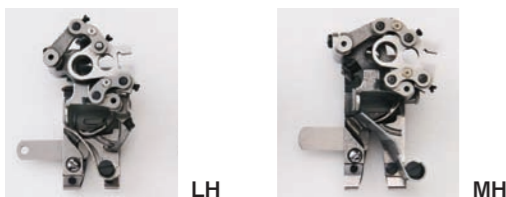

*MHの押さえのナイフはLMのものに比べて上の写真のような厚い生地を切る為、更に幅が厚くなっています。
*The knife of MH pressure foot is much wider than LM in order to cut heavy material like a picture above
*El cuchillo MH del pie de presion es mas ancho que el LM para cortar material mas pesado. Ver foto
*MH和LM押脚的區別是MH押脚能剪厚布(如布样照片)甚至更厚的布料

FSX6604MH-B



4本針上飾り付両切式突合せ縫い用フラットシーマ
(中厚~厚物用)
トレーナー地やフリースなどの厚物地の左右生地を
全く重ねない突合せ縫いにより縫いはすれなくより
フラットで着心地のよいきれいに縫い合わせでき
ます。

4 needle, with top cover stitch, both side
edge cut type flat seamer for butt seams
Suitable for joining heavy materials without
overlapping fabrics so that the seams can
be more flat and beautiful stitch formation.

4 agujas, recubridor superior corte de borde en
ambos lados, costura plana, para union plana,
sin coser sobre arriba de esta manera la costura
es mas plana y la puntada mas bonita.

4 针 6 线 上 装 饰 线 迹 布 边 对 布 边 不 重 叠 缝 曲 臂 双 切
式 缝 机



■ 押えシューズの種類 / FSX Presser foot shoes / FSX Zapatos de prensa tela / 压脚种类

LM-52	LM-60	MH-52	MH-60	S-52	S-60
短いタイプ Short type / Tipo corto / 短款	長いタイプ Long type / Tipo largo / 长款	長いタイプ Long type / Tipo largo / 长款	長いタイプ Long type / Tipo largo / 长款	長いタイプ Long type / Tipo largo / 长款	長いタイプ Long type / Tipolargo / 长款
26-641 26-640	26-644 26-643	26-649 26-648	26-653 26-652		
同梱品 Enclosed / Incluido / 配备品	同梱品 Enclosed / Incluido / 配备品				
長いタイプ Long type / Tipo largo / 长款	短いタイプ Short type / Tipocorto / 短款				
26-655 26-654	26-641 26-640				

MODEL	No. of Needle	No. of Thread	Needle Type		Gauge (Inch)	No. of Stitch (Stitch/Inch)	Diff. Feed Ratio	Presser Foot Lift (mm)	Needle Bar Stroke (mm)	Max. Speed (rpm)
			Organ (#)	Schmetz (Nm)						
FSX-6604S	4+1	6	FL×118GCS 9~12(10)	FLG-8 8	5.2, 6 mm	10~16 (1.6~2.5mm)	1:0.7~1:0.5	8	30	4200
FSX-6604LM	4+1	6	FL×118GCS 9~12(10)	FLG-8 8	5.2, 6 mm	10~16 (1.6~2.5mm)	1:0.7~1:0.5	6	30	4200
FSX-6604MH	4+1	6	FL×118GCS 9~12(10)	FLG-8 8	5.2, 6 mm	10~16 (1.6~2.5mm)	1:0.7~1:0.5	6	30	4200
FSX-6604MH-B	4+1	6	FL×118GCS 9~12(10)	FLG-8 8	5.2, 6 mm	10~16 (1.6~2.5mm)	1:0.7~1:0.5	6	30	4200



PX・MAC SERIES

PXシリーズは、フラットベッド、1本針、2本針二重環千鳥縫いマシンです。

4種類のカム、ゲージを揃えており、2点、3点、4点、5点と千鳥模様を選ぶことができます。また、ピコット縫い、ファゴッティング、さらに新モデルの飾り松葉縫い(フラワーピコット)もラインナップに追加され、婦人服、子供服、ハンカチ、テーブルクロスなどの製品の飾りに最適で、付加価値のある製品に仕上がります。

MAC-100シリーズは、飾り縫いマシンのハイエンドモデルです。当社PXシリーズの4点千鳥でジグザグ模様と飾り松葉縫いを電子制御により多種多様に組み合わせてお客様自身がお好みの模様を創造することができる画期的な製品です。

基盤や内蔵メモリのトラブル発生時もお客様ご自身で簡単に交換、修理することができます。

Tシャツ、ニットウェア、ハンカチなどの縁かがりに使用すれば、独創的な製品が出来上がります。

PX series is flatbed, 1 or 2 needle double chain stitch machine for achieving wishful design. This machine performs zig-zag by the built-in cam that moves the needles left and right (2-5 points). Applications: various designs using picotting and fagotting. Furthermore, newly developed flower stitching machine (Flower Picot) is joined to this series as new model. The outstanding feature of PX is wide variety of decorative stitch patterns using picotting and fagotting. PX series is our best machine for not only women's and children's clothing but also handkerchiefs, table napkins. Your wishful design starts to realize with PX series.

MAC-100 series is a high-end model of decorative stitch machine. This series is epochmaking of PX 4 points zig-zag having a great variety of combination between zig-zag design and flower picotting by electric system. It is so easy to repair and replace by yourself, even in case of trouble in electric chip and built-in memory. Standard model can be used on the edge of T-shirt, knitwear, handkerchief, etc.

Cama plana 1 o 2 agujas, doble cadeneta picoeta, 4 diferentes levas, y varias medidas, Zig-Zag patrones de 2 a 5 puntos para puntadas decorativas, incluyendo la puntada de flor exclusiva de Kansai Special, esta serie es especial para embellecimiento de ropa para senoras, ninos, pauelos, etc.

La serie MAC-100 es una maquina modelo de alta calidad de puntadas decorativas. Esta serie es una maquina Zig-Zag PX de 4 puntos que tiene una gran variedad de combinaciones entre disenos Zig-Zag y puntada de flor por sistemas electricas. El modelo estandar puede ser cosido en el borde de playeras, tejidos, pauelos, etc. y tambien es posible ser cosido por puntadas decorativas completas cambiando algunas partes.

PX 系列是平台式 1 针, 2 针双重环外曲牙缝纫机。4 种齿轮, 针位能缝 2 点, 3 点, 4 点, 5 点外曲牙。

外曲牙, 花形外曲牙, 另外追加了新型的松叶状花形, 最适合女装, 童装, 手帕, 桌布等有附加价值的产品的装饰缝。

MAC-100 系列是装饰缝的高技术型缝纫机。

本公司的 PX 系列的 4 点外曲牙和花形外曲牙通过电子控制产生各种组合花形, 供客户选用。

内藏的电子芯片交换容易, 便于维修。

标准型为各种布料的外边缝, 一部分零件交换后可用于布料中的装饰缝。

PXシリーズ 表示方法

PX	302	4	W
シリーズ名 / SERIES NAME NOMBRE DE SERIE / 系列名称	針数 / NEEDLES AGUJAS / 针数	千鳥数 / ZIG-ZAG POINTS NUMERO DE ZIGZAG / 曲牙数	サブクラス / SUBCLASS SUBCLASE / 特殊装置
	301: 1本針 1 needle 1 agujas 1针 302: 2本針 2 needle 2 agujas 2针	4: 4点千鳥 4 points zig-zag 4 puntos de zig-zag 4点曲牙 5: 5点千鳥 5 points zig-zag 5 puntos de zig-zag 5点曲牙	S: 1本針シングルピコット Single picotte by 1 needle Picueta simple en 1 aguja 1针曲牙 W: 2本針ダブルピコット Double picotte by 2 needles Picueta doble en 2 agujas 2针曲牙

PX302-4W

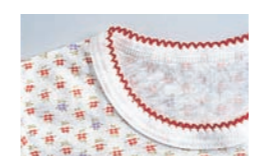
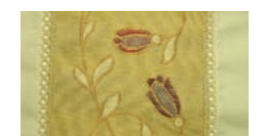
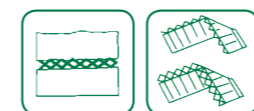

2本針二重環縫い4点千鳥用マシン

2 needle, double chain stitch,
4-point zig-zag machine.

2 agujas, doble cadeneta, 4 puntos
de zig-zag.

2 针双重环缝, 4 点曲牙缝缝机



MODEL	No. of Needle	No. of Thread	Needle Type		Gauge (Inch)	No. of Stitch (Stitch/Inch)	Diff. Feed Ratio	Presser Foot Lift (mm)	NeedleBar Stroke (mm)	Max. Speed (rpm)
			Organ (#)	Schmetz (Nm)						
PX302-4W	2	4	UO×163 11	UY×163GAS 75	2X5.55mm(総振り巾)	0.9mm	0.8~1.5	8	31	3500
PX302-5W	2	4	UO×163 11	UY×163GAS 75	2X7.4mm(総振り巾)	0.9mm	0.8~1.5	8	31	3000

PX301-2S

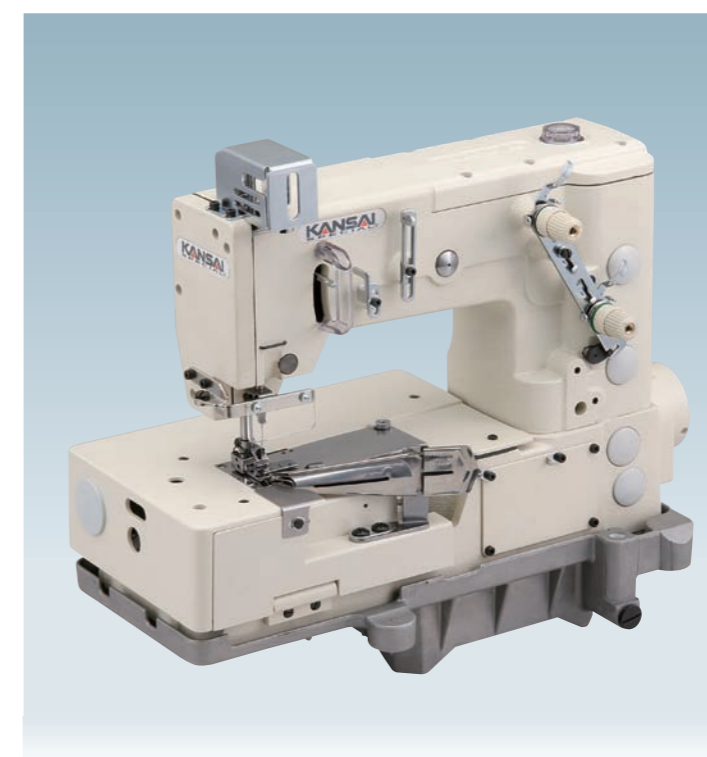
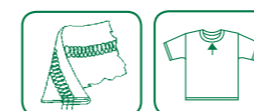

1本針二重環2点千鳥マシン

1 needle, double chain stitch,
2-point zigzag machine

1 aguja, doble cadeneta, 2 puntos
de zigzag.

1 针双重环缝, 2 点曲牙缝缝机

MODEL	No. of Needle	No. of Thread	Needle Type		Gauge (Inch)	No. of Stitch (Stitch/Inch)	Diff. Feed Ratio	Presser Foot Lift (mm)	NeedleBar Stroke (mm)	Max. Speed (rpm)
			Organ (#)	Schmetz (Nm)						
PX301-2S	1	2	UO×163 11	UY×163GAS 75	3.5mm(総振り巾)	1.75mm	0.8~1.5	8	31	3000

PX302-5W



2本針二重環5点千鳥ミン
 2 needle, double chain stitch, 5-point zigzag machine.
 2 agujas doble cadeneta; 5 puntos (4 pasos) maquina de zig-zag.
 2 针双重环缝, 5 点曲牙缝缝纫机

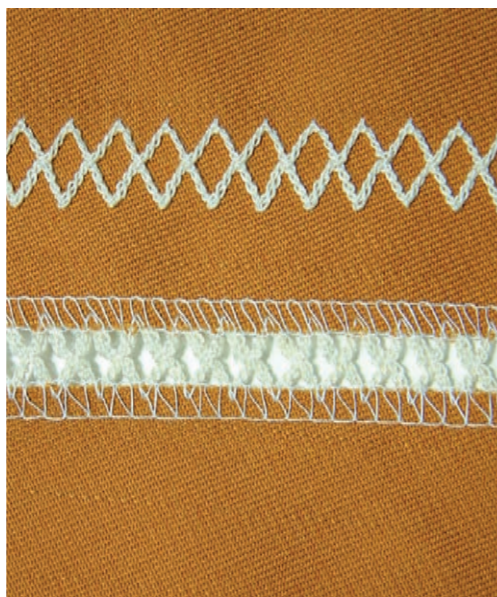
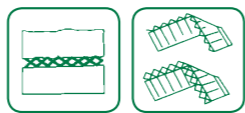

PX302

-

4W

•

5W

SINGLE PICOTTING	DOUBLE PICOTTING	FAGOTTING

MAC100



飾り縫いのハイエンドモデルです。PXシリーズの4点千鳥でジグザグ模様と飾り松葉縫いを電子制御により多種多様に組み合わせお客様自身がお好みの模様を作り出すことのできる画期的な商品です。

High end model of decorative stitch machine. Epock making of PX 4 points zig-zag having a great variety of combination between zig-zag design and flower picotting by electric system.

Una maquina modelo de alta calidad de puntadas decorativas. Zig-zag PX de 4 puntos que tiene una gran variedad de combinaciones entre direnos zig-zag y puntada de flor por sistema eletrica.

电子外曲牙和花型机
 外曲牙和花形缝的组合, 产生各种花形缝, 通过电子控制产生各种装饰缝花样。

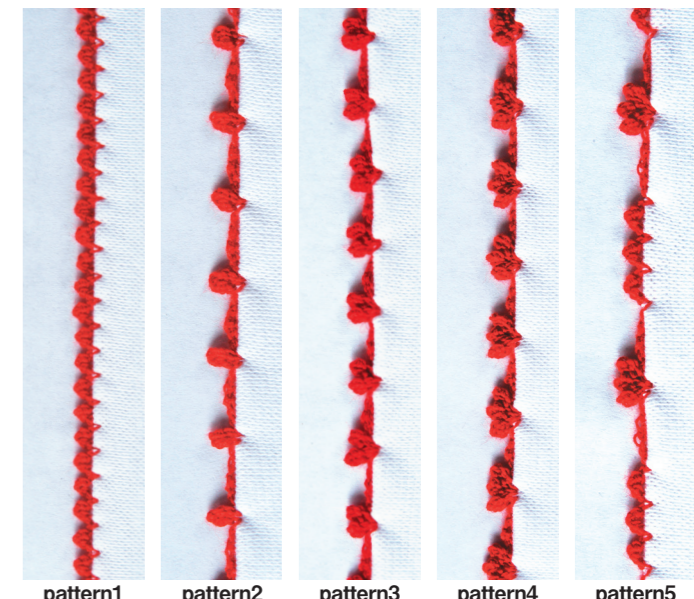
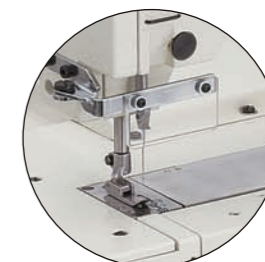

MODEL	No. of Needle	No. of Thread	Needle Type		Gauge (Inch)	No. of Stitch (Stitch/Inch)	Diff. Feed Ratio	Presser Foot Lift (mm)	NeedleBar Stroke (mm)	Max. Speed (rpm)
			Organ (#)	Schmetz (Nm)						
MAC100	1	2	UO×163 11	UY×163GAS 75	5.55mm(総振り巾)	12	0.8~1.5	8	31	2000



MMX SERIES

飾り縫いには定評があるKANSAI SPECIALから、より高速で安定性のある新しいスモック飾り縫いマシンが誕生しました。婦人服、子供服、下着、スポーツウェア等の地縫いおよびテープ付け縫いに最適です。

従来モデルはカムの種類が3種類でしたが、このMMXシリーズでは更に3種類を追加し、計6種類のカムを用意しています。

また、そのカムの交換も非常に簡素化され、カムの振り板(スプレッダー)を微調整する必要をなくしました。振り板を上下2段式にすることによりスモッキング糸が生地に対してより自然にフィットします。

This new smocking machine with high speed and stabilized performance is just released from KANSAI SPECIAL who has a reputation in the field of decorative sewing machine. Most suitable for hemming and taping such as lady's wear, children's wear, underwear, sportswear and so on. 6 kinds of standard cams are available as the conventional model. Very easy to change the cam. No need to adjust the spreaders. The smocking threads fit with the fabric naturally by adopting dual oscillating spreaders.

Esta es nueva maquina de puntada decorativa(smocking) de alta velocidad, KANSAI SPECIAL. Acaba de introducirla al mercado es indicada para ropa de senora, niños, ropa deportiva. 3 clases de leva son standar en los modelos convencionales, en esta serie nueva de MMX hay 3 levas opcionales, para hacer diferentes aplocaciones, y es muy facil hacer el cambio de leva, no es necesario ajustar los esparcidores. El hilo para la puntada decorativa, se adopta a la tela muy facilmente, debido a que tiene 2 etapas de los esparcidores de arriba, y abajo.

装饰缝收到好评的 KANSAI 开发出更高速的安定性强的新装饰缝的缝纫机。用于女装, 童装, 内衣, 运动服等服装, 并可用于滚领。MMX 系列在以前的 3 种花盘的基础上追加了 3 种花盘。并且花盘交换简易化, 不需要做微调整。装饰板上下两段分开, 使装饰缝迹更与布料吻合。

MMX3303F

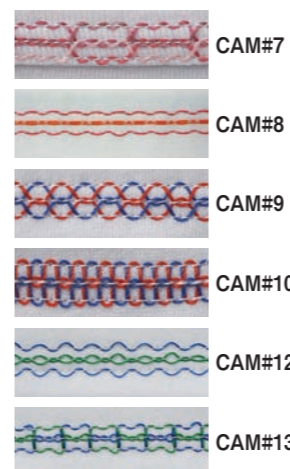

3本針下面飾りテープ付け用スモッキングマシン

3 needle, bottom cover stitch machine with smocking for tape binding.

3 agujas, recubridor inferior, puntada decorativa para pegar cintas.

3 针装饰缝滚领缝纫机

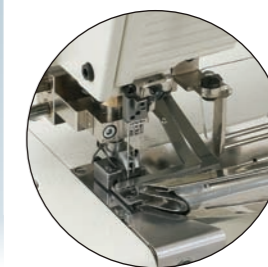

MODEL	No. of Needle	No. of Thread	Needle Type		Gauge (Inch)	No. of Stitch (Stitch/Inch)	Diff. Feed Ratio	Presser Foot Lift (mm)	Needle Bar Stroke (mm)	Max. Speed (rpm)
			Organ (#)	Schmetz (Nm)						
MMX3303F	3	6~10	UYX128GAS 9~14	UYX128GAS 60~90	7/32, 1/4	8~16	0.7~2	6	31	3500

カムの種類及び模様 | Smocking Description / Descripción de Smocking / 横盘的种类和缝制模样

カム No. CAM No.	飾り糸ループ - (上) / Top Smocking Looper	飾り糸ループ - (下) / Bottom Smocking Looper	飾り糸ループ - (上) / Top Smocking Looper	飾り糸ループ - (下) / Bottom Smocking Looper	飾り糸ループ - (上) / Top Smocking Looper	飾り糸ループ - (下) / Bottom Smocking Looper	飾り糸ループ - (上) / Top Smocking Looper	飾り糸ループ - (下) / Bottom Smocking Looper
No. 7 品番 PART No. 04-357								
No. 8 品番 PART No. 04-358								
No. 9 品番 PART No. 04-359								
No. 10 品番 PART No. 04-360								
No. 12 品番 PART No. 04-362								
No. 13 品番 PART No. 04-363								

MMXシリーズ 表示方法

MMX	33	03	F
シリーズ名 SERIES NAME NOMBRE DE SERIE 系列名称		針数 NEEDLES AGUJAS 针数	サブクラス SUBCLASS SUBCLASE 特殊装置
		03:3本針 3 needle 3 agujas 3针	D:標準 Standard Estandar 标准 F:テープ付け用 For binding tape Para pegar cinta 滚领用

BX1033PSM-WMD

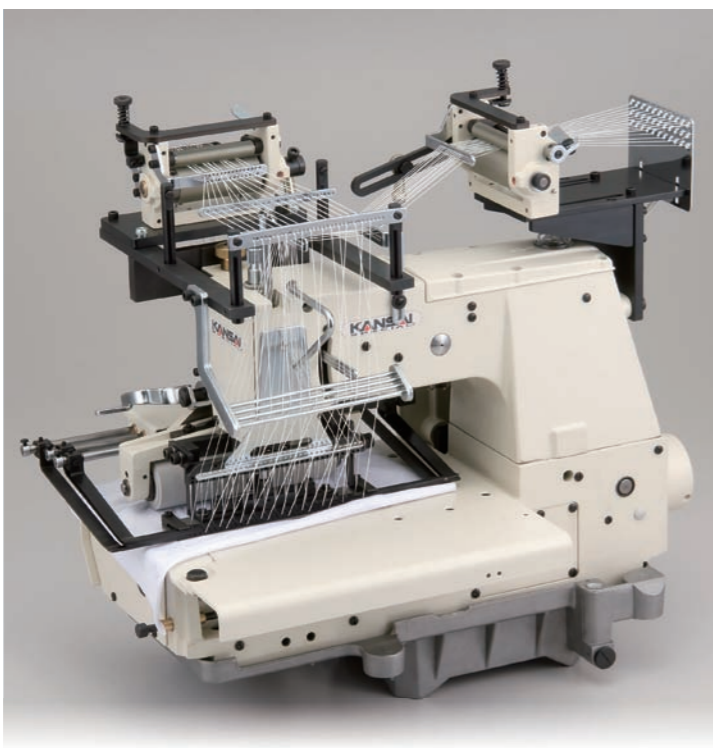

33本針単環縫い、プラー付きスモッキングマシン。針糸用と飾り糸用にそれぞれゴム送り装置を装備し、安定かつ美しいゴム系スモッキングを作ることができます。

33 needle, flatbed single chain stitch machine with puller, for smocking and equipped with 2 independent metering devices. It can make beautiful smocking patterns with stability.

33 agujas, con puntada decorativa. Equipado 2 arrastradores independientes, se puede hacer puntada decorativa bella.

3 3 针带后拉拖单线锁链底打搅缝纫机。使用两个独立式送松紧带装置实现线迹稳定。

■ BX-WMD のゴム系送り装置

針糸、飾り糸はゴム系送り装置により安定した縫製が可能になります。
 BX-WMD can beautifully sew with using elastic thread by metering device.
 BX-WMD puede coser bellamente con usar el hilo elástico por dispositivo de elastico.
 针线，装饰线可以通过利用橡筋线送线装置来稳定缝制的线迹



■ 針糸用送り装置

Metering device for needle thread
 Dispositivo de elastico para el hilo de la aguja
 装饰线用送线装置

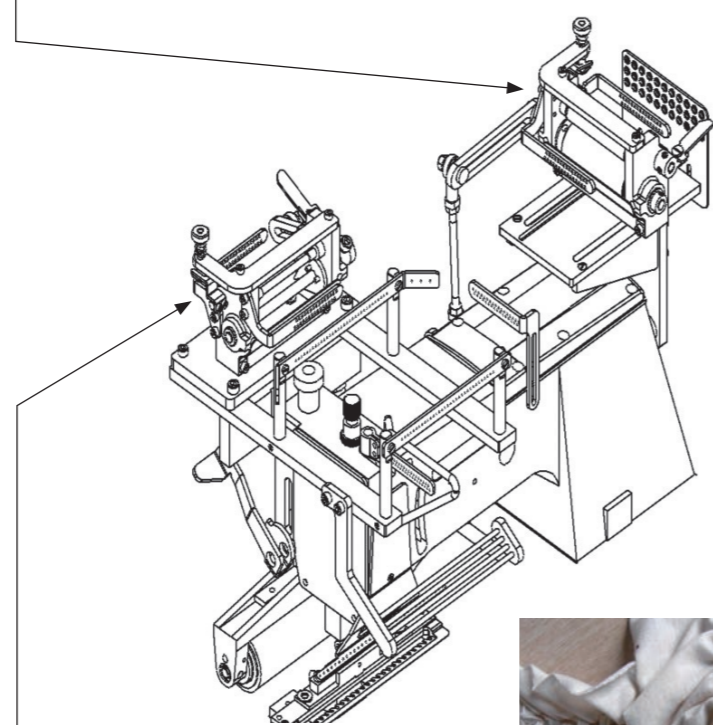

■ 飾り糸用送り装置

Metering device for smocking thread
 Dispositivo de elastico para el hilo del smocking
 针线送线装置



WX8803D-WD

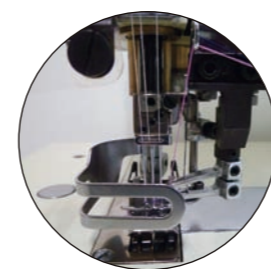

3本針上面ダブル飾り下面飾り縫い地縫いマシン

3 needle, flatbed, high speed dual top and bottom cover stitch machine for plain seam

3 agujas, cama plana, alta velocidad, doble recubridor superior y recubridor inferior para puntada regular.

3 针上面双重装饰缝下面绷缝缝纫机

■ いろいろなダブル上面飾り縫い

SEVERAL KINDS OF DUAL STITCHES / Varios tipos de doble recubridor superior / 3种款式的上面双重装饰

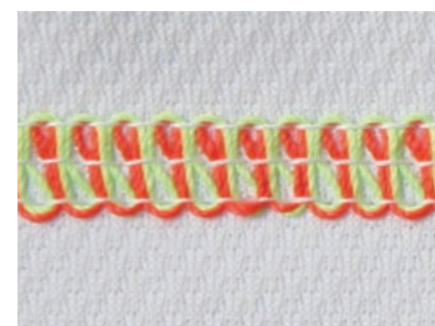

● オール&オール-2重飾り
 All & all -Dual stitch
 Todo y todo-doble recubridor superior
 全部双重装饰缝或者全部混合双重装饰缝



● ハーフ&ハーフ-2重飾り
 Half & half -Dual stitch
 Mitad y mitad-doble recubridor superior
 全部双重装饰缝或者半边混合装饰缝

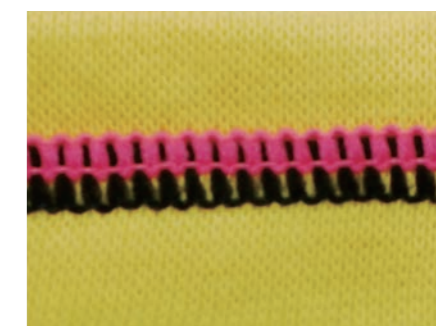

● オール&ハーフ-2重飾り
 All & half -Dual stitch
 Todo y mitad-doble recubridor superior
 半边双重装饰缝或者混合半边装饰缝

部品の取り換えにより上のような3種のデザインが可能です。
 Above 3 kinds of designs are available by changing several parts
 Por encima de 3 tipos de diseños están cambiando varias partes
 根据更换零件可以达到以上3种款式

RX9803CC-WD

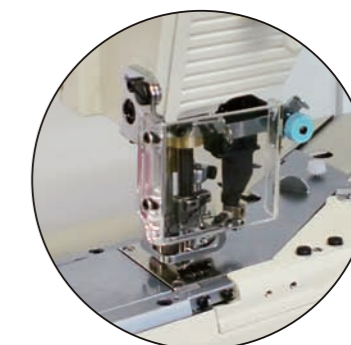

UK SERIES

KANSAI SPECIALオリジナルのオーバーロックマシン“UK”シリーズがリニューアルしました。

UK2000シリーズは1本針から3本針までのオーバーロック、インターロックマシンです。

特徴 ① クローズドタイプの針棒機構 ② 針糸、針冷却装置を標準装備 ③ マイクロアジャスト方式の差動調節 ④ 低振動、低騒音 などに加えてサブモデル、オプションも豊富で拡張性も高く、経済性を重視したモデルです。また、モーターをマシン本体に直接接続したダイレクトモーター仕様も新たに加わり、さらなる省電力・低振動を実現しています。

KANSAI SPECIAL “UK2000 Series” is launched now with numerous modifications. The new UK is 1 to 3 needles overlock and interlock machine. It contains a number of new features and benefits.

Major features are as follows: ① Closed type (fully sealed) needle bar drive mechanism. ② Built-in needle & thread cooler ③ Fine adjustable differential feed ④ Low vibration, low noise

In this new series we can offer also the direct drive, that can save more energy and realize less-vibration, low noise.

Fresh thinking, user-friendly design, operating the brand new KANSAI SPECIAL's UK machine makes your work neat and clean.

KANSAI SPECIAL “La serie UK2000” es lanzado con tantas modificaciones.

Esta nueva serie UK viene de 1 a 3 agujas con puntada de seguridad.

Las características mayores tales como : ① El mecanismo de la barra de agujas, esta completamente cerrado

② Sistema de enfriador de agujas/agujas interior ③ Ajuste para la alimentacion del diferencial ④ Minima vibracion, minimo ruido

Se puede equipar el motor directo en esta nueva serie que ahorra energia electrica y realiza minima vibracion, minimo ruido.

La nueva serie UK de Kansai Special hace que su trabajo sea nitido y limpio.

UK 系列有 1 针至 3 针的包缝和安全缝包缝机。

特性 ① 密闭式的针杆结构 ② 针线和机针的冷却装置为标准装备 ③ 微对准方式的差动调节 ④ 低振动，低噪音 还可以加配多款装置和自选装置 UK 系列非常重视机器的扩充性和经济性

UK2005S-10M



1本針オーバーロックマシン裾引き用
主にTシャツ、下着などの裾縫いに最適です。

1 needle, overlock machine for blind hemming.
Mainly, suitable for T-shirts, underwear, and etc.

1 aguja para hacer un dobladillo de brind.
Conveniente para la camiseta,ropa interior,etc.

1 针 3 线折下摆缝包缝机，最适宜 T 恤，内衣等折下摆
横边缝。

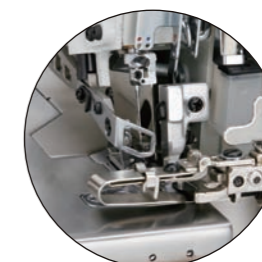
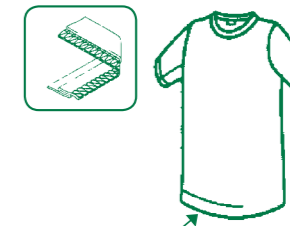

UK2014H-01M UK2014H-40M



2本針オーバーロックマシン地縫い用(01M)、
テープ付け用(40M)
主に薄物から中厚までのTシャツ、40Mはニット製品の
肩帯テープ付けに最適です。

2 needle, overlock machine 01M for plain sewing
and 40M for attaching tape.
Suitable for sewing light to medium heavy-weight
materials such as T-shirts, knit wear, and etc.

2 agujas,maquina de overlock para pegar
cinta.Conveniente para materiales delgados
tales como camiseta,prendas de punto,etc.

2 针 4 线肩带包缝机 (01M, 40M)，最适宜从薄料到中
厚料的 T 恤等针织产品的缝肩带用 (2014H-40M)



UK2014H-01M UK2014H-40M

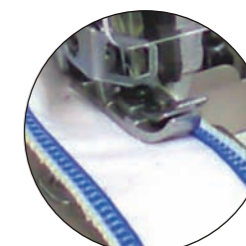
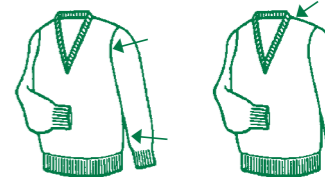

UKシリーズ モデル表示方法

シリーズ名 SERIES NAME NOMBRE DE SERIE 系列名称	縫目形式 / SEAM TYPE TIPO DE COSTURA / 线迹形式	生地厚さ MATERIAL THICKNESS ESPESOR DE MATERIAL 布料的厚度	針幅 GAUGE SIZE CALIBRE DE AGUJAS 针距	かがり幅 SEAM WIDTH ANCHO DE COSTURA 边距	ダイレクトモーター DIRECT MOTOR MOTOR DIRECTO 直驱马达
UK20: オーバーロック Overlock Overlock 包缝机	04: 1本針3本糸 地縫い 1 needle, 3 thread for plain seaming 1 aguja, 3 hilos ostura sencilla / 一般縫	F: 薄物 Light Liviano 薄料	2: 2mm 3: 3mm 5: 5mm	1: 1.5mm 3: 3mm 4: 4mm 5: 5mm	
UK21: インターロック Interlock Puntada de seguridad 安全縫包缝机	05: 1本針3本糸 裾引き 1 needle, 3 thread for hemming 1 aguja, 3 hilos dobladillo / 卷边缝	X: 極厚物 Ultra heavy Ultrapesado 极厚料			
	14: 2本針4本糸 地縫い 2 needle, 4 thread for plain seaming 2 agujas, 4 hilos costura sencilla / 一般縫	M: 薄物~中厚 Light to medium Liviano - mediano 薄料, 中厚料			
	16: 2本針5本糸 安全縫い 2 needle, 5 thread safety stitch 2 agujas, 5 hilos puntada de seguridad / 安全縫	H: 厚物 Heavy Pesado 厚料			
	43: 3本針6本糸 安全縫い 3 needle, 6 thread safety stitch 3 agujas, 6 hilos puntada de seguridad / 安全縫				

縫容量 SEWING CAPACITY CAPACIDAD DE COSIDO 线迹长短	用途 / APPRICATIONS / APLICACIONES / 用途	アタッチメント / ATTACHMENT DISPOSITIVOS / 针位特殊配件
S: スタンダード Standard lift Levantador regular 标准运动量	01: 地縫い Plain seaming Costura sencilla 普通縫	VTC: 縦型空環切装置 Vertical type chain cutter Cortador vertical 垂直气压吸入式自动切剪 空线链装置
H: ハイリフト High lift Levantador alto 高转速	10: ヘム縫い Hemming Dobladillo 折下摆	ETC: テープカッター Tape cutter Corta cinta 切布条装置
	20: 巻縫い Turn down hemming Doblar ribete 卷边缝	GA: ギャザリング装置 Gathering device Dispositivo de fruncido 褶皱装置
	30: ギャザリング Gathering Fruncido 打折缝	HTC: 横型空環切装置 Horizontal type chain cutter Cortador horizontal 水平气压吸入式自动切剪 空线链装置
	40: テープ付け Tape binding Pegar cinta 滚条	
	50: バックタック Back tack Dispositivo posterior "atacador" 线头包缝	
	02: 丸物縫い Tubular specification Especificacion tubular 圆物缝	
	03: トラクターフット付き Tractor foot built in Pie tractor 厚料用防跳线	

UK2116S-30M



2本針安全縫いミシンひだ取り用
主にカーテン、エプロンなどのシャーリングに最適です。

2 needle, safety stitch machine for shirring.
Suitable for sewing light to medium heavy-weight materials such as curtains, aprons, and etc.

2 agujas, puntada de seguridad, para fruncir cortinas, delantales, etc.

2针5线打褶安全缝包缝机。最适宜窗帘、围裙等的打褶用。



UK2000H-WG

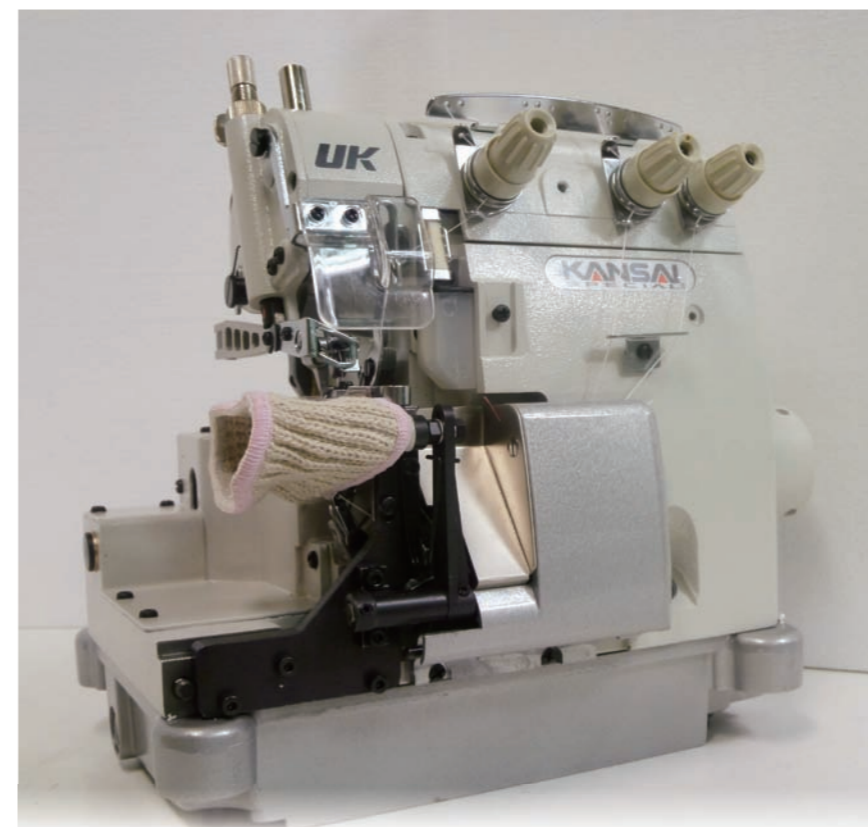

1本針オーバーロックミシン軍用手(手首部分)

1 needle overlock machine for work gloves (wrist part).

1 aguja, maquina de overlock para guante de trabajo (parte de muñeca)

1针手套专用包缝机。(用于手腕部分)



UK2116H-03X



2本針安全縫いミシン極厚物用

2 needle, safety stitch machine for extra heavy materials.

2 agujas, maquina de puntada de seguridad para materiales extra pesados.

2针5线安全缝包缝机。适用于厚料。

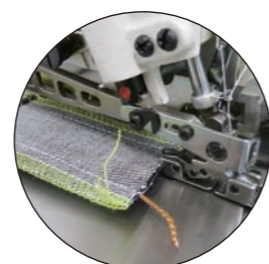
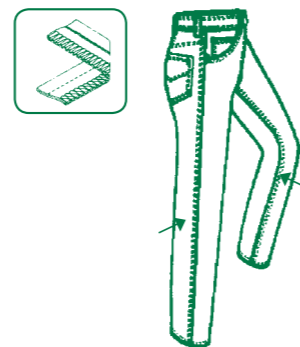

UK2004S-20F



1本針縁かがり用オーバーロックミシン

1 needle overlock machine for turn-down hemming.

1 aguja, maquina de overlock para doblar ribete.

1针卷缝包缝机

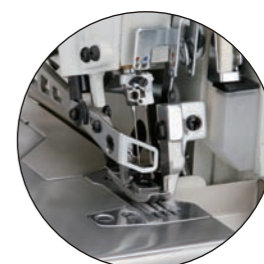

UK2143H-90M-3x2x4



3本針多用途インターロックミシン

3 needle multi-purpose interlock machine.

3 agujas, maquina de puntada de seguridad para multi uso.

3 针安全缝包缝机

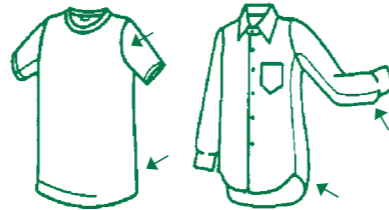

UK-DM

ダイレクトモーター仕様のオーバーロック、インターロックミシン
ベルト駆動に比べ、さらなる省電力・低振動・低騒音を実現しました。
KANSAI SPECIAL UKシリーズすべてに適合します。

Overlock and Interlock machine with DIRECT MOTOR are less energy,
less vibration and less noise comparing with the belt-driven machine.
It suits for all models of the KANSAI SPECIAL UK.

Se puede equipar el motor directo en todas series UK2000 que
ahorra energia electrica y realiza minima vibracion, minimo ruido.

机体带电动机装置的包缝机实现了省电又
低振动，低噪音关西的UK系列全能使用

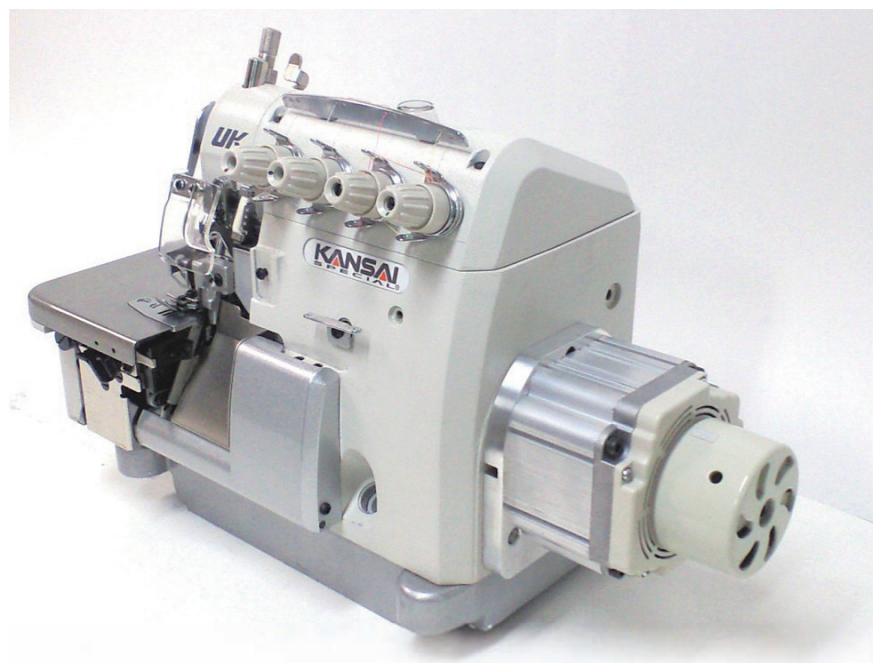

UK SERIES | TECHNICAL DATA 仕様明細

Subclass	Gauge size	Application	Fabric weight	Type of needle DCx27	No. of Needle	No. of threads	Needle space (mm)	Overedge width (mm)	Stitch length (mm)	Feed dog type	Pitch of feed dog (mm)	Diff. Feed ratio	Presser Foot Lift (mm)	Max. Speed (rpm)	Chain cutter	Remarks
<p>1 本針オーバーロック SINGLE NEEDLE OVERLOCK MACHINE</p>																
UK2000H-WG		work glove		#18	1	3~4		4	3				8	5000		
UK2004S-01M	-4	plain seaming 地縫い	light to medium 薄物~中厚	#11	1	3		4	1~3.8		1.6	0.7~2	6	6500	VTC	
UK2005S-10M	-3	hemming 裾引き	light to medium 薄物~中厚	#9	1	3		3	1~3.8		1.6	0.7~2	6	6500	VTC	
	4															
UK2004S-20F	-1	turn down hemming 巻き縫い	light to medium 薄物~中厚	#9	1	3		1.5	1~3.8		1.6	0.7~2	6	6500	VTC	
UK2004S-50M	-3	backlatching バックタック	light to medium 薄物~中厚	#11	1	3		3	1~3.8		1.6	0.7~2	6	6500		
	4															
<p>2 本針オーバーロック 2 NEEDLES OVERLOCK MACHINE</p>																
UK2014H-01M	-2x2	plain seaming 地縫い	light to medium 薄物~中厚	#11	2	4	2	2	1~3.8		1.6	0.7~2	6	6500	HTC	
	-2x3							3								
	-2x4							4								
	-2x5							5								
UK2014H-40M-2x4	-2x4	tape binding テープ付け	light to medium 薄物~中厚	#11	2	4	2	4	1~3.8		1.6	0.7~2	6	6500	HTC	
	-2x5							5								
UK2014H-50M-2x4	-2x2	backlatching バックタック	light to medium 薄物~中厚	#11	2	4	2	2	1~3.8		1.6	0.7~2	6	6500		
	-2x3							3								
	-2x4							4								
	-2x5							5								
<p>2 本針安全縫ミシン 2 NEEDLES SAFETY STITCH MACHINE</p>																
UK2116S-01M	-3x4	plain seaming 地縫い	light to medium 薄物~中厚	#11	2	5	3	4	1~3.8		1.6	0.7~2	6	6500	HTC	
UK2116S-02M	-3x4	plain seaming 地縫い	light to medium 薄物~中厚	#11	2	5	3	4	1~3.8		1.6	0.7~2	6	6500	HTC	foot for tubular structure 小廻り用押え付き
UK2116S-01H	-5x5	plain seaming 地縫い	heavy 厚物	#11	2	5	5	5	1~3.8		1.6	0.7~2	6	6500	HTC	
UK2116H-03X	-5x5	plain seaming 地縫い	ultra heavy 極厚物	#21	2	5	5	5	1~5		2.5	0.7~1.4	7	5500	HTC	tractor foot トラクターフット
	-5x6							6								
UK2116S-30M	-3x4	gathering ギャザー	light to medium 薄物~中厚	#11	2	5		3	1~3.2		1.6	0.8~3	6	5500		
	-5x6							5								
	-3x4P							3								
<p>3 本針安全縫ミシン 3 NEEDLES SAFETY STITCH MACHINE</p>																
UK2143H-90M-3x2x4		plain seaming 地縫い	light to medium 薄物~中厚	#11	3	6	3x2	4	1~3.8		1.6	0.7~2	6	6000		

|"DOUBLE CHAIN" シリーズ用 オプション |

OPTIONS FOR DOUBLE CHAIN SERIES / OPCION PARA DOUBLE CHAIN SERIES / 双重环系列的附属品

■ B, BLX (B-2000, BLX2200)



■ BK-20 ベルトループカッター
Automatic cutting device for belt loops.
Cortador para pasadores.
切带装置

■ SX



■ CS-2 空環切り装置 (写真はFSX用で類似品)
ELECTRIC CHAIN CUTTER
CORTADOR DE CADENETA
切空线头装置

■ DLR

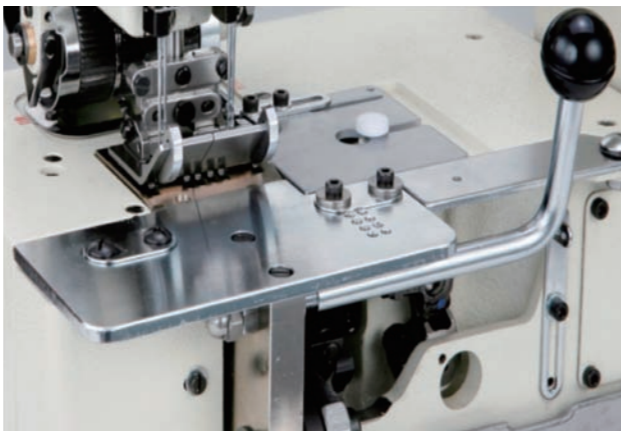

■ TB ターンダウンホルダーブラケット (*1508SPF,1509SPFは標準装備)
TURN DOWN FOLDER BRACKET (*This is standard equipment for 1508SPF,1509SPF)
EQUIPAMENTO ESTANDAR (PARA 1508SPF, 1509SPF)
拉开式面板 (1508SPF, 1509SPF 标准装备)

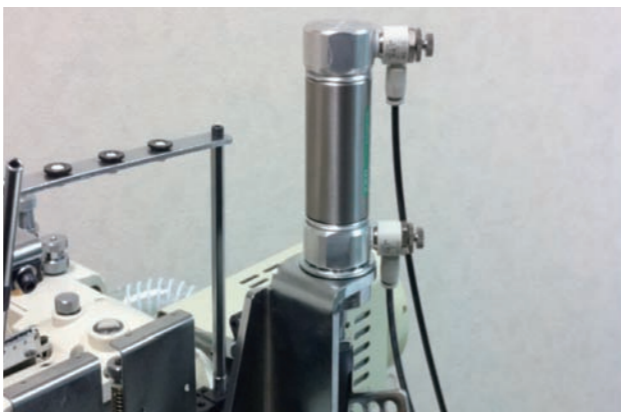

■ FL エアー式押え上装置
AIR TYPE FOOT LIFTER
LEVANTA PIE NEUMATICO
气压式抬压脚装置

|"Multi-needle" シリーズ用 オプション |

OPTIONS FOR MULTI-NEEDLE SERIES / OPCION PARA MULTI-NEEDLE SERIES / 多针机的附属品

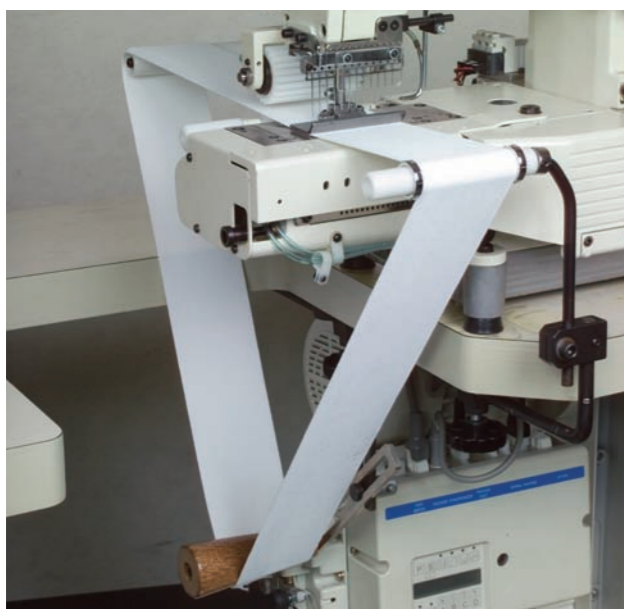

■ RT-1 ゴム張り装置 (手動式)
DX, FX (PSF, PMD, PLは除く), RX (RX-P, PLKのみ)
RT-1 Elastic expander device (manual operation)
DX, FX (except for PSF, PMD, PL), RX (Only for RX-P, PLK)
RT-1 EXPANDIDOR DE ELASTICO DX, FX, RX
松紧带撑开装置 (DX,FX, 除PSF, PMD, PL, RX-P, PLK)

|"TOP & BOTTOM" シリーズ用 オプション |

OPTIONS FOR TOP & BOTTOM SERIES / OPCION PARA TOP&BOTTOM SERIES / 绷缝系列特殊配件

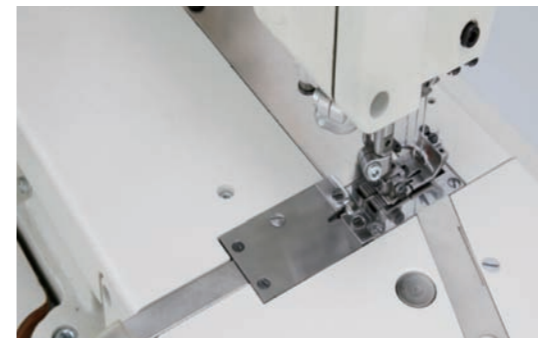

■ CS-1 空環切り装置 (VD 集塵装置は別売り)
AIR TYPE CHAIN CUTTER (Except for VD -Venturi device)
CORTADOR DE CADENETA
切空线头装置



■ VD 集塵装置
VENTURI DEVICE
APARATO ASPIRADOR
吸尘装置



■ EW 電気式上糸払い
(電気式ワイパー WX, RX, NM 用)
ELECTRIC TYPE WIPER FOR WX, RX, NM
DESLIZADOR ELECTRICO PARA WX, RX, NM
电动式上勾线



■ AW エアー式上糸払い
(エアー式ワイパー WX, RX, NM 用)
AIR TYPE WIPER FOR WX, RX, NM
DESLIZADOR NEUMATICO PARA WX, RX, NM
气动式上勾线



■ MC-30 電気式テープカッター (WX-F, WX-15用)
ELECTRIC TAPE CUTTER
(For WX-F, WX-15)
APARATO DE CORTA CINTA,
TIPO ELECTRICO
(PARA WX-F, WX-15)
电动式切布装置



■ CS-2 空環切り装置 (FSX用)
ELECTRIC CHAIN CUTTER (For FSX)
CORTADOR DE CADENETA PARA FSX
切空线头装置



■ FL エアー式押え上装置
AIR TYPE FOOT LIFTER
FL: LEVANTA PIE NEUMATICO
气压式抬压脚装置

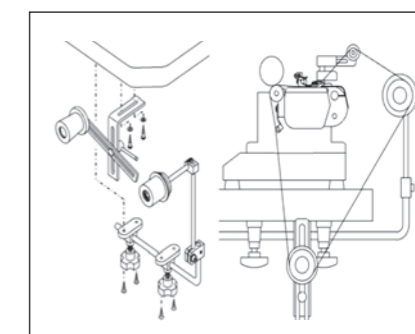

■ RT-1 ゴム張り装置 (手動式) RX-PHK
Elastic expander device
(manual operation) RX-PHK
EXPANDIDOR DE ELASTICO RX-PHK
松紧带撑开装置

■ 00-6604 FSX 太径パイプ bigger diameter pipe (For FSX)



標準装備 / STANDARD DEVICE
EQUIPAMENTO ESTANDAR / 标准配件

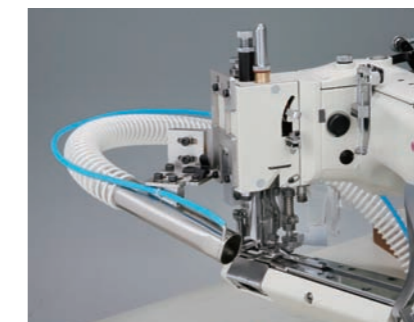

オプション / OPTION
OPCIÓN / 选项

■ VD
バキューム装置は標準装備 (FSX用) 但し、写真右の太径は厚物用にオプション (パーツNo.00-6604)
Vacuum equipment is standard device. (For FSX) But, in case of thick material, the bigger diameter pipe (PartsNo.00-6604) is available as per attached picture.
Aparato de succion es equipamento estandar. Pero, en caso de material pesado, el tubo de diametro mas grande (parts No.00-6604) es disponible segun la foto adjunta.
吸尘装置

|"Overlock" シリーズ用 オプション |

OPTIONS FOR OVERLOCK SERIES / OPCION PARA OVERLOCK SERIES / 包缝系列的附属零件



■ VD 集塵装置
VENTURI DEVICE
APARATO ASPIRADOR
吸尘装置

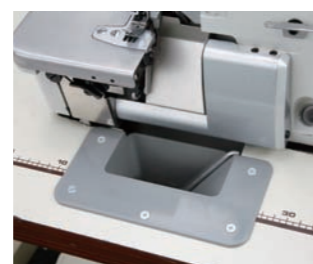

■ UK シリーズオプション組合せ
COMBINATIONS OF OPTIONAL DEVICES

	PATTERN 1	PATTERN 2	PATTERN 3
VD	○	○	○
HTC / VTC	○	○	
FL	○		○
AIR REGURATOR	○	○	○

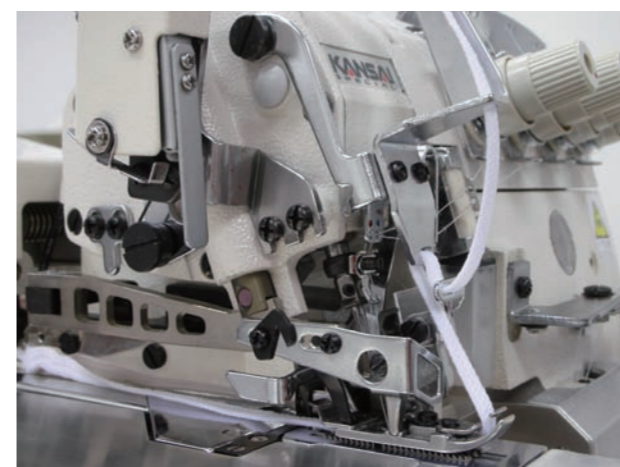

■ ETC-3 電気式テープカッター
ELECTRIC TAPE CUTTER FOR UK
CORTADOR DE LA CINTA ELECTRICO PARA UK
电动式切布装置



■ VTC 縦型空環切り装置
VERTICAL CHAIN CUTTER
(chain off is cut and is sucked by air at side behind the needle plate)
CORTADOR DE CADENETA, TIPO VERTICAL
纵向切线装置

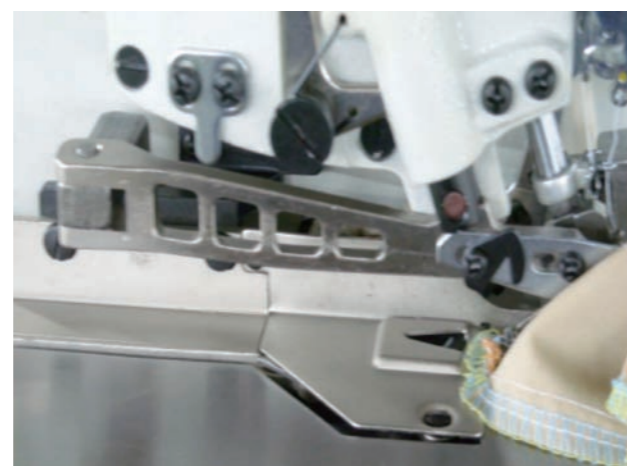

■ HTC 横型空環切り装置
HORIZONTAL CHAIN CUTTER
(chain off is cut and is sucked by air horizontally behind the needle plate)
CORTADOR DE CADENETA, TIPO HORIZONTAL
横向切线装置

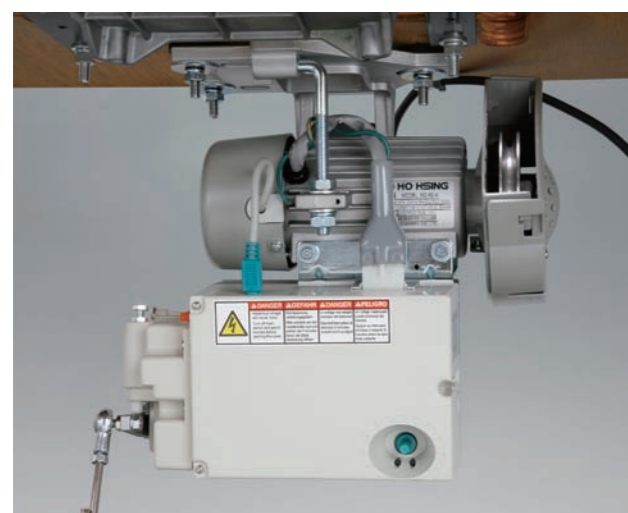

■ MJ-1 簡易型サーボモーター
ECO SERVO MOTOR
Servo motor sencillo
简易马达



■ FL エアー式押上装置
AIR TYPE FOOT LIFTER
LEVANTA PIE NEUMATICO
气压式抬压脚装置